

Part Number	Description	PG	Item Number
AG3233	MF RES 0W5 21R5 F TC50 2,5-7	01	RA 437
AG3273	MF RES 0W5 56R2 F TC50 2,5-7	01	RA 315
AG3343	MF RES 0W5 274R F TC50 2,5-7	01	RA 280
AG3433	MF RES 0W5 2K15 F TC50 2,5-7	01	RA 343
AG3465	MF RES 0W5 4K64 F TC50 2,5-7	01	RA 134 446 447
AG3473	MF RES 0W5 5K62 F TC50 2,5-7	01	RA 345
AG3477	MF RES 0W5 6K19 F TC50 2,5-7	01	RA 204
AG3489	MF RES 0W5 8K25 F TC50 2,5-7	01	RA 307
AG3501	MF RES 0W5 10K0 F TC50 2,5-7	01	RA 271 338
AG3519	MF RES 0W5 15K4 F TC50 2,5-7	01	RA 461
AG3525	MF RES 0W5 17K8 F TC50 2,5-7	01	RA 339
AG3557	MF RES 0W5 38K3 F TC50 2,5-7	01	RA 308
AG3609	MF RES 0W5 121K F TC50 2,5-7	01	RA 323
AG3619	MF RES 0W5 154K F TC50 2,5-7	01	RA 149
AG3643	MF RES 0W5 274K F TC50 2,5-7	01	RA 415
AJ2523	MO RES 2W0 10R J 6-17	02	RA 428
AJ2763	MO RES 2W0 100R J 6-17	02	RA 351 359 367 375 436
AJ2863	MO RES 2W0 270R J 6-17	02	RA 142 144
AJ3425	MO RES 4W0 56K J 9-22	03	RA 126
AQ2214	TPMET.AA H10 1K0 RM 5X10 6-HOLE	03	RTA 401
AQ2347	TPMET. H10 10K RM 5X10 6-HOLE	04	RTA 101
AQ2219	TPMET.AA H10 47K RM 5X10 6-HOLE	03	RTA 301
AW0079	PTC-THERMISTOR 18R/25'C RM5	07	PTCA 002
AW0111	NTC-THERMISTOR 5R0/25'C RM5+2,5	07	NTCA 001
QH0065	RELAY PCB-MOUNTING 12V 5A/250V	12	REA 001
CA0324	CERCAP Y5P 100P K 1KV Y5 D8 L	02	CA 148 150 154 323 424 425 446
CB0418	CERCAP N150 22P J 500V Y5: D8	01	CA 532
CC0170	CERCAP Y5P 470P K 500V Y5: D8	01	CA 419
CC0240	CERCAP Y5P 2N2 K 500V Y5: D9	01	CA 120 157 318 322 426
CC0513	CERCAP Y5V 3N3 S 1KV Y7,5 D14	02	CA 109 110 111 112 410
CC0530	CERCAP Z5U 4N7 S 500V Y5: D9	01	CA 162
CC0772	CERCAP Z5V 10N Z 50V Y5: D8	01	CA 334
CE0081	X2-CAP 220N K 250VAC Y20 121725	08	CA 100
CE0116	Y-CAP 2N2 M 400VAC Y12,5 SDPJ16	04	CA 101 102 103 107 108 115
CB3129	CHIPCERCAP NP0 15P 50V J 0805	03	CA 517 518
CB3133	CHIPCERCAP NP0 22P 50V J 0805	01	CA 339
CB3141	CHIPCERCAP NP0 47P 50V J 0805	01	CA 534 248 533
CB3145	CHIPCERCAP NP0 68P 50V J 0805	01	CA 302
CB3151	CHIPCERCAP NP0 100P 50V J 0805	01	CA 124 301 303 313 535 536
CB3159	CHIPCERCAP NP0 220P 50V J 0805	01	CA 406 427
CB3163	CHIPCERCAP NP0 330P 50V J 0805	01	CA 123 314 501
CB3167	CHIPCERCAP NP0 470P 50V J 0805	02	CA 122 409
CB3171	CHIPCERCAP 680P	02	CA 209
CB3173	CHIPCERCAP NP0 820P 50V J 0805	02	CA 109
CB3175	CHIPCERCAP NP0 1N0 50V J 0805	03	CA 242 308 321 210 125
CC0530	CERCAP Z5U 4N7 S 500V Y5: D9	01	CA 420
CC3240	CHIPCERCAP X7R 2N2 10% 50V 0805	01	CA 405
CC3260	CHIPCERCAP X7R 3N3 10% 50V 0805	01	CA 249
CC3280	CHIPCERCAP X7R 4N7 10% 50V 0805	01	CA 234 338 415 128
CC3320	CHIPCERCAP X7R 10N 10% 50V 0805	01	CA 126 129 335 133 204 214
CC3320	CHIPCERCAP X7R 10N 10% 50V 0805	01	CA 241 304 341 404 511 553 541 544
CC3320	CHIPCERCAP X7R 10N 10% 50V 0805	01	CA 503 542 543
CC3360	CHIPCERCAP X7R 22N 10% 50V 0805	01	CA 202
CC4400	CHIPCAP X7R 47N K 50V 1206	02	CA 207 208 502
CC4855	CHIPCAP Y5V 100N Z 50V 1206	03	CA 119 132 216 227 232 316 324 337 402 436
CC4855	CHIPCAP Y5V 100N Z 50V 1206	03	CA 437 438 439 440 441 442 529 206 218 561
CC4855	CHIPCAP Y5V 100N Z 50V 1206	03	CA 562 563
CE2435	IMPCAP 15N J 400V Y10 061113	03	CA 429
CE2671	IMPCAP 33N J 400V Y15 061118	04	CA 430 443
CE2802	IMPCAP 51N J 400V Y15 081418	03	CA 421 422 423
CE2852	IMPCAP 68N J 400V Y15 081418	04	CA 431
CE2964	IMPCAP 150N K 250V Y15	05	CA 432
CE3063	IMPCAP 330N J 250V Y22,5 111928	05	CA 433
CE3163	IMPCAP 680N J 250V Y22,5 112128	07	CA 434
CE3223	"IMPCAP 1U2 J 250V""G""Y22,5 091928"	07	CA 435
CE0522	PCACAP MKC 100N J 63V Y5: 040808	04	CA 413
E2004	IMPCAP 100P K 1K6V Y15 051118	03	CA 142 147
CE2094	IMPCAP 820P K 1K5V Y15 061218	04	CA 307
CE2196	IMPCAP 2N2 J 2KV Y22,5 081628	06	CA 416 417
CE2671	IMPCAP 33N J 400V Y15 061118	04	CA 418
CE2931	IMPCAP 100N 250V Y15 081418	04	CA 306
CG2663	PPRCAP KP 4N7 H 63V Y5: 060808	04	CA 127 408
CK0165	PESCAP MKT 22N K 630V Y10 061213	02	CA 116 117
CK0341	PESCAP MKT 220N K 100V Y10 051113	03	CA 233
CK1388	PESCAP MKT 10N K 250V Y7,5 040911	02	CA 305 407
CK1546	PESCAP MKT 47N K 100V Y7,5 040911	02	CA 246
CK2545	PESCAP 47N K 63V Y5: 030708	02	CA 312
CK2626	PESCAP MKT 100N K 63V Y5: 030808	02	CA 156 336
CK2663	PESCAP MKT 150N J 63V Y5: 040908	03	CA 225
CK2704	PESCAP MKT 220N K 63V Y5: 040908	03	CA 551
CK2784	PESCAP MKT 470N K 63V Y5: 051008	03	CA 228 319
CK2864	PESCAP MKT 1U0 K 50V Y5:061108!	05	CA 403
CN0118	ELCAP 150U M 400V R10 SNAP 25X40	16	CA 113 114
CN0204	ELCAP 2U2 M 50V RM5: 6*12	01	CA 444 445 509
CN0204	ELCAP 2U2 M 50V RM5: 6*12	01	CA 519 520 521 522 523 524 528
CN0819	ELCAP 2200U M 25V RM7,5 105*17X38	05	CA 149 151 155
CN2017	ELCAP 1U0 M 50V RM5: 105*6X12	02	CA 139 317 515 131 212

Part Number	Description	PG	Item Number
CN2027	ELCAP 47U M 50V RM5: 105' 9X12	02	CA 205 226
CN2029	ELCAP 4U7 M 100V RM5: 105' 6X12	03	CA 245
CN2032	ELCAP 10U M 50V RM5: 105' 6X12	01	CA 152 153 158 159 510 516 401 118 311
CN2037	ELCAP 10U M 160V RM5 105' 11X21	04	CA 144
CN2461	ELCAP- 47U M 100V RM5 105, 10X16	04	CA 121
CN2543	ELCAP 100U M 50V RM5 105 11X13	02	CA 146 160 161 215 230 320 428 412 217
CN2546	ELCAP 100UF M 100V RM5 105' 14X21	05	CA 143
CN2553	ELCAP 0U47F M 50V RM5: 105' 6X12	01	CA 211 552
CN2566	ELCAP 4U7F M 50V RM5: 105'6X12MM	02	CA 203 325
CN2581	ELCAP 220U M 35V RM5 105 11X13	03	CA 229 231
CN3250	ELCAP, 47U M 250V RM7,5 105'16X25	05	CA 140 141 411
CN3402	ELCAP,1000U M 16V RM5 +105'13X34	12	CA 414
FJ0274	CHOKO 1,0UH	02	LA 407
FJ0448	CHOKO 13UH FERRITE 2X15	02	LA 104 105
FJ0505	CHOKO 15UH 5% TAPED AXIAL	02	LA 103 106
FJ0517	CHOKO 6.8UH 10% TAPED AXIAL	02	LA 101
FJ0730	LEAD INDUCTOR 270UH 10%	03	LA 302
FJ0725	BEAD INDUCTOR MIN IMP360HM	02	FRA 401 402
FJ0733	LEAD INDUCTOR 56UH 10 %	07	LA 401 402 406
FJ0735	LEAD INDUCTOR 82UH 10% Y=5MM	07	LA 405
FJ0800	EMI/RFI CHOKO 60MH 3A(AC)	14	MA 101
FM0636	FLYBACK TRAF0 30..120KHZ 445T	38	MA 301
FJ1826	INPUT CHOKO E30/7 2X6,9 MH	12	MA 102 103
FM2560	DYNAMIC FOCUS TRAF0 E20/6 445R	12	MA 404
FM2569	CENTERING COIL E30/7 1.32UH 445T	12	MA 403
FM2570	DRIVER TRAF0 E20/6 N67 17.2U 445T	12	MA 402
FM2571	INPUT TRAF0 ETD34 N87 382UH 445T	20	MA 401
FM3505	SMPs-TRAF0 ETD49 N67 445T	19	MA 104
FU0721	FIXED LINEARITY COIL N-S 445T	08	LA 403
FU0722	FIXED LINEARITY COIL S-N 445T	15	LA 404
JF0025	DI 1N4148 75V 200MA 4N	01	DA 204 208 209 401 402 406 302 303 129
JF0025	DI 1N4148 75V 200MA 4N	01	DA 429
JF0025	DI 1N4148 75V 200MA 4N	01	JA 117
JF0060	DI 1N4002 100V 1A	01	DA 207
JF0206	SCHOTTKY RECTIFIER 30V 1A 1N5818	04	DA 405
jF0072	DI BAV21 200V 250MA 50N	01	DA 128 205 315 432 108
jF0096	DI BYV28-100 100V 3.5A 30N	07	DA 126 413 421 422
JF0166	DIODE BYM26C 600V 2.3A SOD-64	06	DA 122 123
JF0171	DI BYV29-400 400V 8A 50NS TO-220	09	DA 125
JF0032	DI UF4007 1000V 1A 75N DO41/SOD57	04	DA 105 409
JF0033	DI UF5404 400V 3A 50NS	04	DA 127
JF0034	DI UF5406 600V 3A 75N	09	DA 306
JF0073	DI RGP10G 400V 1A 150N	02	DA 418 419 420 427 416 423 424
JF0104	DI BYV27-200 200V 2A 25N SOD57	03	DA 411 412 430
JF0106	DI UF2D-7000 200V 2A 50N MUOVI	03	DA 106
JF0107	DI BYV26C 600V 1A 30N	05	DA 426
JF4003	DI BAV103 200V 250MA 50NS SOD-80	07	DA 407 408 431
JF4005	DI LL4148 75V 150MA 4N (JF4006)	01	DA 107 109 110 120 121 201 206 210 211 301
JF4005	DI LL4148 75V 150MA 4N (JF4006)	01	DA 304 305 307 316 317 318 403 404 212
JF4005	DI LL4148 75V 150MA 4N (JF4006)	01	DA 504 507 508 417 428 130
JF4011	SCHOTTKY BARRIER 30V 200MA SOT-23	03	DA 202
JF4101	DI RHRD460S 600V 4A 30NS TO-252	08	DA 124 410
JB0044	DI DTV110F 1500V 10A TO220FI	14	DA 414
JB0047	DI GP30M 1000V 3A 3,0US DO201AD	04	DA 101 102 103 104
JH0053	ZDI BZX83C5V6 5.6V 0.5W 5%	01	DZA 101
JH0054	ZDI BZX83C12 12V 0.5W 5%	01	DZA 402 404 405 103
JH0059	ZDI BZX83C8V2 8.2V 0.5W 5%	01	DZA 102
JH0169	ZDI BZX55B3V9 3.9V 0.5W 2%	03	DZA 502
JH0085	ZDI BZX83C22 22V 0.5W 5%	01	DZA 201
JH0086	ZDI BZX83C4V7 4.7V 0.5W 5%	02	DZA 403
JH4118	ZDI BZX84C12 12V 0.35W 5%	02	DZA 301
JM0099	TR BC547B N 45V 100A 200M:	01	TA 301 305 307
JM0100	TR BC557B P 45V 100A 200M:	01	TA 115 302 306
JM0203	TR MPSA42 N 300V 500MA TO92	03	TA 415 416
JM0205	TR BF423 P 250V 25MA 60M:	03	TA 112
JM0206	TR BF420 N 300V 100MA 60M TO-92:	12	TA 417
JM0227	TR MPS2369 N 15V 200MA 500M	03	TA 207 405
JM0239	TR BC638 P 60V 1A 50M:	04	TA 103
JM0244	TR BF422 N 250V 25MA 60M:	02	TA 311 410 425
JM0252	TR BC639-10 N 100V 1.5A TO92	03	TA 412
JM0273	TR 2N5551 NPN 160V 0.6A	02	TA 104 205 206
JM0280	TR 2N5401 P 150V 0.6A 100M	02	TA 411
JM0334	TR BD135 NPN 45V 1A5 250MHZ TO126	04	TA 328 330 334
JM0335	TR BD136 PNP 45V 1A5 250MHZ TO126	04	TA 329 331 335
JM4105	TR BC847B N 45V 0.1A SOT23	04	TA 117 118 203 312 315 316 319 324
JM4105	TR BC847B N 45V 0.1A SOT23	04	TA 327 404 406 208 508
JM4114	TR BC857B P 45V 100MA 150M:	02	TA 102 106 107 116 509 426 310 313 314 317
JM4114	TR BC857B P 45V 100MA 150M:	02	TA 318 325 326 401 402 407 506
JM0341	TR BUH1215(435B) N 1500V 19ATO218	19	TA 409
JS1006	FET BS170 N 60V 500MA	10	TA 111
JS0019	FET IRF640 N 200V 18A TO220	13	TA 420 421 422 423 424
JS0019	FET IRF640 N 200V 18A TO220	13	TA 418 419
JS0026	FET IRFBC40 N 600V 6.0A TO220 AB	12	TA 403
JS0030	FET IRF620 200V 5A 0.8R TO-220	07	TA 413 414
JS0035	FET IRF820 N 500V 2.5A 3.0R	10	TA 113
JS0049	FET 2SJ306 P 250V 3A 1.5R TO220	19	TA 303
JS0051	FET IRF9540 P 100V 19A 0.2R TO220	14	TA 408
JS0062	FET IRFPC50 N 600V 11A OR60 TO247	17	TA 105

Part Number	Description	PG	Item Number
JS0063	FET IRFIBE30G N 800V 2,1A 3R0 220	23	TA 304
LM4406	IC LM324 QUAD OP-AMP SO-14	05	ICA 304
LM0893	IC 74HC14N 6XINV.SCHMITT-TRIGGER	05	ICA 502
LM0921	IC SI-3120F 12V LOWDROP REG	10	ICA 105
LM4111	IC 4538BT	05	ICA 301
LM0067	IC UA7805UC +5V REGULATOR TO-220	13	ICA 104 106
LM4022	IC 74HCT74 DUAL D-FLIP-FLOP SO-14	05	ICA 503
LM4111	IC 4538BT	05	ICA 506
LM0930	IC STV9379 VERT.DEFL.BOOSTER	15	ICA 203
LM0340	IC TDA2040V AUDIO POWER AMPLIFIER	14	ICA 302
LM0663	IC TL431 VOLTAGE REFERENCE TO-92	06	ICA 103
LM0931	IC MAS1012 DYN.CONV.CONTROL IC	21	ICA 303
LM0938	IC ST72E72 MONITOR UC,DDC DIP-56	34	ICA 501
LM0957	IC UC3843 CURR.MODE PWM CON.DIP-8	06	ICA 401
LM0945	IC 24C65 SERIAL EEPROM 8X8K DIP-8	16	ICA 504
LM0959	IC L4990 PRIMARY CONTROLLER DIP16	10	ICA 101
LM0962	IC TDA9106 DEFLECTION PROCESSOR	19	ICA 201
LZ0003	IC-SOCKET 8-POLE DIL SINGLE LEAF	03	ICA 504
LZ0063	IC-SOCKET 56-POLE DUAL LEAF 1.78	10	ICA 501
JL0066	OPTOCOUPLER CNX82A 3750VRMS	07	ICA 102
SE0928	YLITYSLANKA D=0,6 L=50MM	01	RA 312
SE0928	YLITYSLANKA D=0,6 L=50MM	01	LA 102
SE2530	POWER SYNC. JOHTO 447C	08	MA 301
QK1446	WIRE TERMINAL FOR 1,85MM HOLES	01	002
SE2643	VERT. JOHTO 445R	06	VA 001 002
AC4400	CHIPRES 0W1 0R0 5% 0805 2013	01	JA 802 803 804 806 809 810
AC4400	CHIPRES 0W1 0R0 5% 0805 2013	01	JA 811 812 815 818 819 820 823
QA0095	CRYSTAL 8,00 MHZ HC-49/U	04	XA 501
QT0002	SPARK GAP 1,2KV +-500V R=5,0MM	03	GLA 302 303
QT0207	GLIMM LAMP 95V 6*12,5MM	04	GLA 301
QT0102	FUSEHOLDER CLIPS 5*20MM R=5,0MM	01	FA 101
QT0775	FUSE 5*20MM T 6,3A 250V 1500A	03	FA 101
QT0733	FUSE R=5,0MM T 3,15A 250V IEC127	04	FA 102
AA0665	CF RES 0W25 470R J 2,5-7	01	RZ 603
AA0697	CF RES 0W25 10K J 2,5-7	01	RZ 607
AC4449	CHIPRES 0W1 100R 5% 0805 2013	01	RZ 604
AC4457	CHIPRES 0W1 220R 5% 0805 2013	01	RZ 608
AC4473	CHIPRES 0W1 1K0 5% 0805 2013	01	RZ 602
AC4481	CHIPRES 0W1 2K2 5% 0805 2013	01	RZ 605 609
AC4465	CHIPRES 0W1 470R 5% 0805 2013	01	RZ 601
AC4513	CHIPRES 0W1 47K 5% 0805 2013	01	FOL
AC4497	CHIPRES 0W1 10K 5% 0805 2013	01	RZ 606
AP0191	PMET 10K LIN EVJ02KFB6B14 CCLICK	10	PZ 602 603
JL0058	LED DUALCOLOR RED/GREEN 3 MM	04	LEDZ 601
JL0061	LED GREEN MPG3372X 3MM	03	LEDZ 602 603
JM4105	TR BC847B N 45V 0.1A SOT23	04	TZ 601
JF4005	DI LL4148 75V 150MA 4N (JF4006)	01	DZ 601
QG0329	MINIATURE PUSH SWITCH 0.1A 24VDC	10	SWZ 601 602
QG0401	ENCODER 20PULSE/360° WITH SWITCH	14	PZ 601
QM1005	PICOFLEX ASSY BI-IDC 16-POS 120MM	11	QZ 601
QK1059	PIN STRIP 1X03	03	QA 301
QK1415	CRIPLET CONN FOR 2-SIDED PCB	01	
QK1285	ROW CONN 1X05 5,08/7,62 VERT/LOCK	03	QA 102
QK1287	PIN STRIP 1X04 8,0/10,0 VERT MALE	03	QA 401
QK1531	PIN STRIP 1X08 2,5 VERT	04	QA 302
QK1587	COOLING & SUPP.PART FOR RESISTOR	01	RA 126
QK1650	MAINS CONN MALE 90DEG W/PCB SNAPS	08	QA 101
QK1707	PICOFLEX HEADER 1X16 1,27MM	04	QA 505
UC1140	COOLING PLATE PN45154 KUPAR	02	TA 113 303 304 403 408 420
UC1140	COOLING PLATE PN45154 KUPAR	02	TA
UC1140	COOLING PLATE PN45154 KUPAR	02	ICA 104 105 106 302
UC1140	COOLING PLATE PN45154 KUPAR	02	DA 125
UC6564	COOLINGPLATE 449A PN303153	05	TA 105
UC6564	COOLINGPLATE 449A PN303153	05	ICA 203
UC6647	COOLING PLATE 445X	09	TA 328 329 330 331 334 335
XE0057	COPPER FLATCABLE 0,5*50MM	22	
UC6664	COOLING PLATE 445X	14	TA 421 422 423 424
XE0057	COPPER FLATCABLE 0,5*50MM	22	
UC6784	COOLING PLATE PN410058 447E	04	DA 124
UC6912	J HD.LEVY/COOLING PLATE 445T	10	TA 409
UC6912	J HD.LEVY/COOLING PLATE 445T	10	DA 414
UC0859	FASTENING SPRING PN44473	02	TA 113 303 304 403 408 420 421 422 423
UC0859	FASTENING SPRING PN44473	02	TA 424
UC0859	FASTENING SPRING PN44473	02	ICA 104 105 106 302
UC0859	FASTENING SPRING PN44473	02	DA 125
UC6551	FASTENING SPRING	03	DA 414
UC6551	FASTENING SPRING	03	ICA 203
UC6552	FASTENING SPRING	03	TA 105 409
UC6668	FASTENING SPRING TO126	02	TA 328 329 330 331 334 335
UC6743	SUPPORT 447E/H	06	
UC6752	WASHER 447E	01	MA 301
UC6752	WASHER 447E	01	
UC6893	SUPPORT 445P	05	
UJ0125	LEAD BAND SST 1 M	01	
JZ0005	SILICONE INSUL. PAD 19*13*0.22MM	01	ICA 203
JZ0018	SILIC/AL INSUL. WITH GLUE 19*13	03	TA 113 403 408 420 421 422 423 424
JZ0018	SILIC/AL INSUL. WITH GLUE 19*13	03	ICA 104 106 302
JZ0018	SILIC/AL INSUL. WITH GLUE 19*13	03	DA 125

Part Number	Description	PG	Item Number
JZ0012	SILICONE INSUL. 22*30*0.22MM	04	TA 105 409
JZ0017	SILICONE INSUL.10X13X0,22 TO-126	02	TA 328 329 330 331 334 335
QM1006	PICOFLEX ASSY BI-IDC 16-POS 550MM	12	QA 502
QM1007	PICOFLEX ASSY BI-IDC 10-POS 500MM	10	QA 501
WC0353	PT-SCR KB 40X10 WN1447 FE/ZN YELL	01	MA 301
WC0446	SCREW 2,9X8 FE/ZN	01	
WC0530	SCREW AV ZNYEL 2,9X11,5	02	MA 301
XW0032	L_MP.JOHT.RASVA DOW CORNING	32	TA 105 409
XW0032	L_MP.JOHT.RASVA DOW CORNING	32	DA 414
XW0032	L_MP.JOHT.RASVA DOW CORNING	32	ICA 203

SMA193E



D3122E 05.97 Page 48

445T

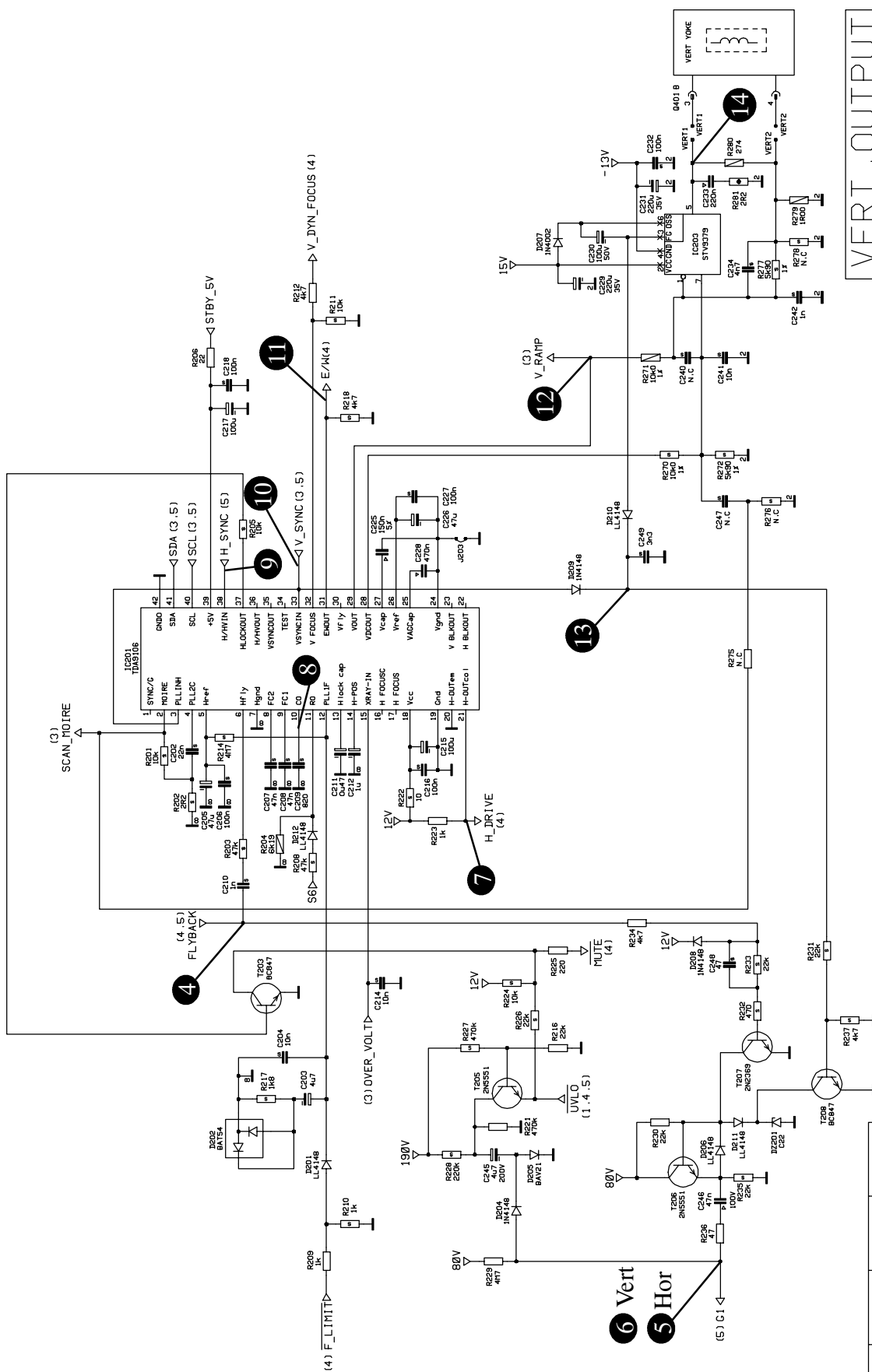

DEFLECTION PROCESSOR

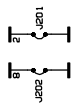

ECN 55610



Symbol	Material	Value
	CERAMIC	<< 63 V
	POLYPROPYLENE	<< 63 V
	POLYESTER	<< 160 V
	POLYESTER	<< 250 V
	POLYESTER	<< 500 V
	POLYESTER	<< 1,5 KV

DYN. KONVERGENZ

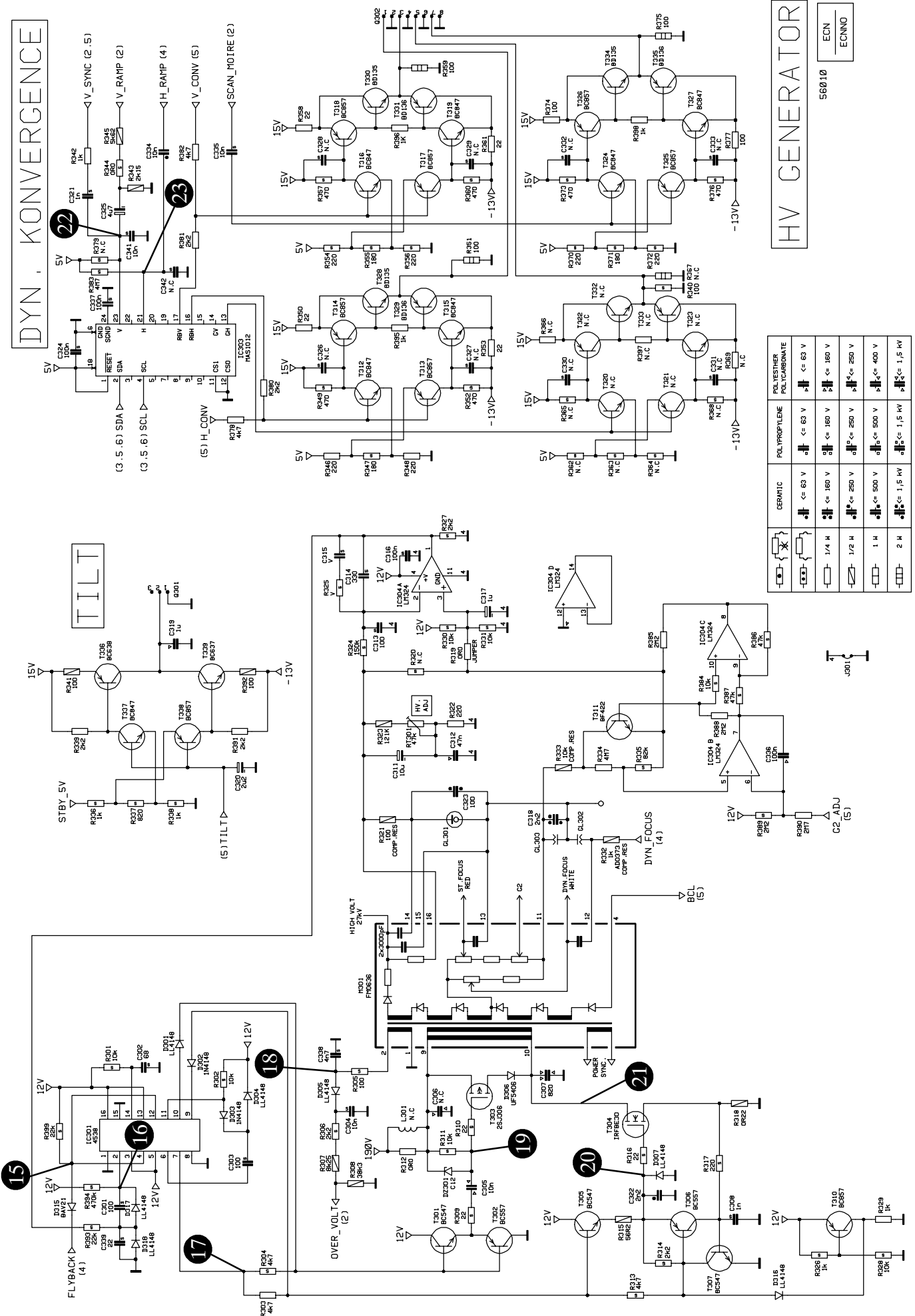

HV GENERATOR

ECN 56010
ECNNO

Symbol	CERAMIC	POLYPROPYLENE	POLYESTHER	POLYCARBONATE
	<= 63 V	<= 63 V	<= 63 V	<= 63 V
	<= 180 V	<= 180 V	<= 180 V	<= 180 V
	<= 250 V	<= 250 V	<= 250 V	<= 250 V
	<= 500 V	<= 500 V	<= 500 V	<= 500 V
	<= 1,5 kV	<= 1,5 kV	<= 1,5 kV	<= 1,5 kV

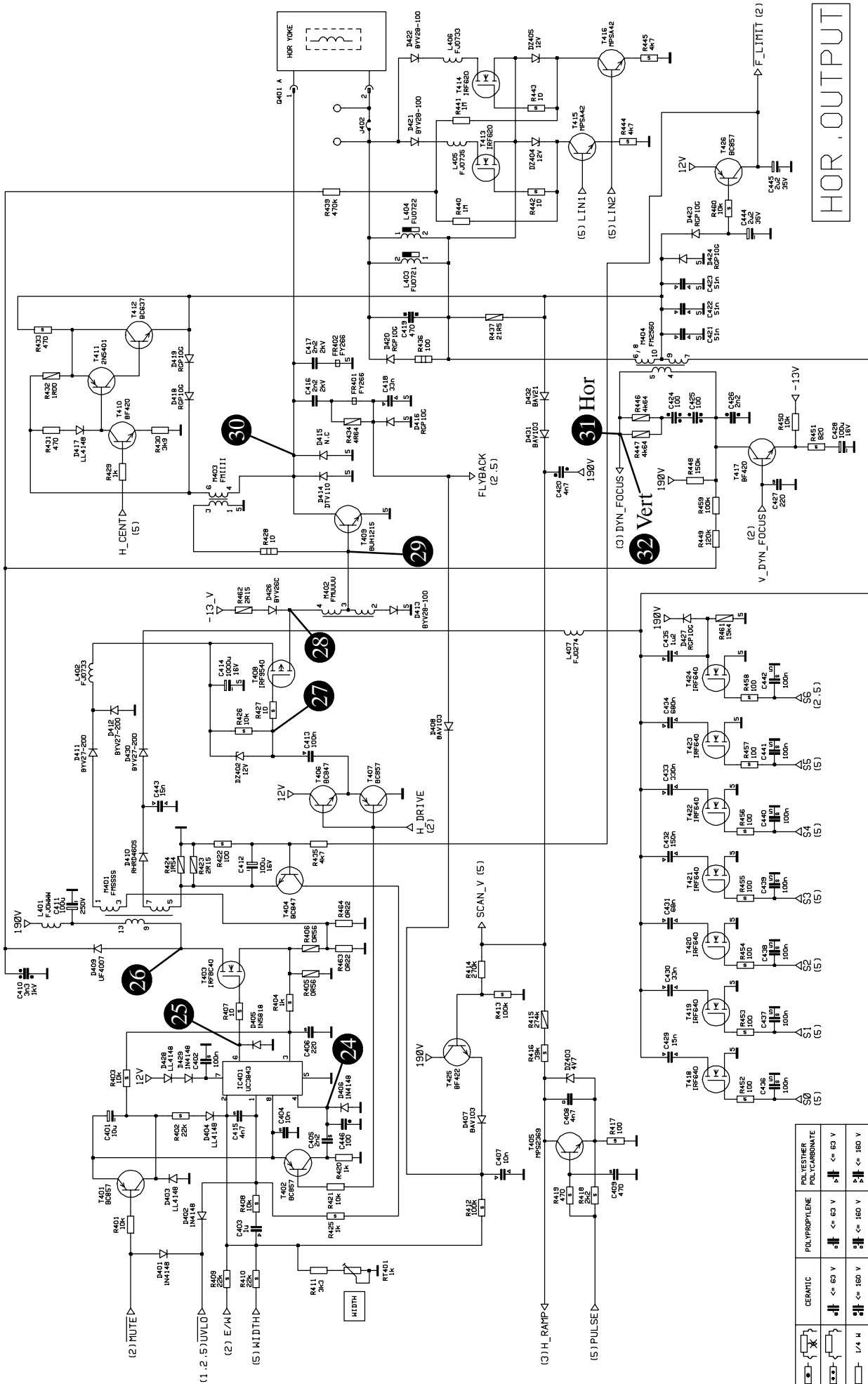

56010

ECN
ECNN

J401

Symbol	CERAMIC	POLYPROPYLENE	POLYESTER/POLYCARBONATE
	$\ll 63 \text{ V}$	$\ll 63 \text{ V}$	$\ll 63 \text{ V}$
	$\ll 180 \text{ V}$	$\ll 180 \text{ V}$	$\ll 180 \text{ V}$
	$\ll 250 \text{ V}$	$\ll 250 \text{ V}$	$\ll 250 \text{ V}$
	$\ll 300 \text{ V}$	$\ll 300 \text{ V}$	$\ll 300 \text{ V}$
	$\ll 1.5 \text{ kV}$	$\ll 1.5 \text{ kV}$	$\ll 1.5 \text{ kV}$

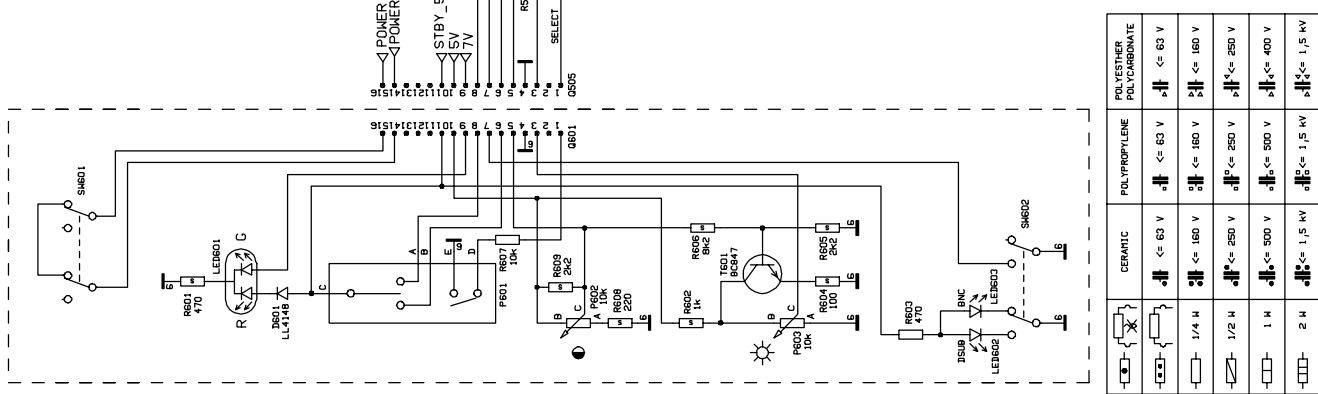
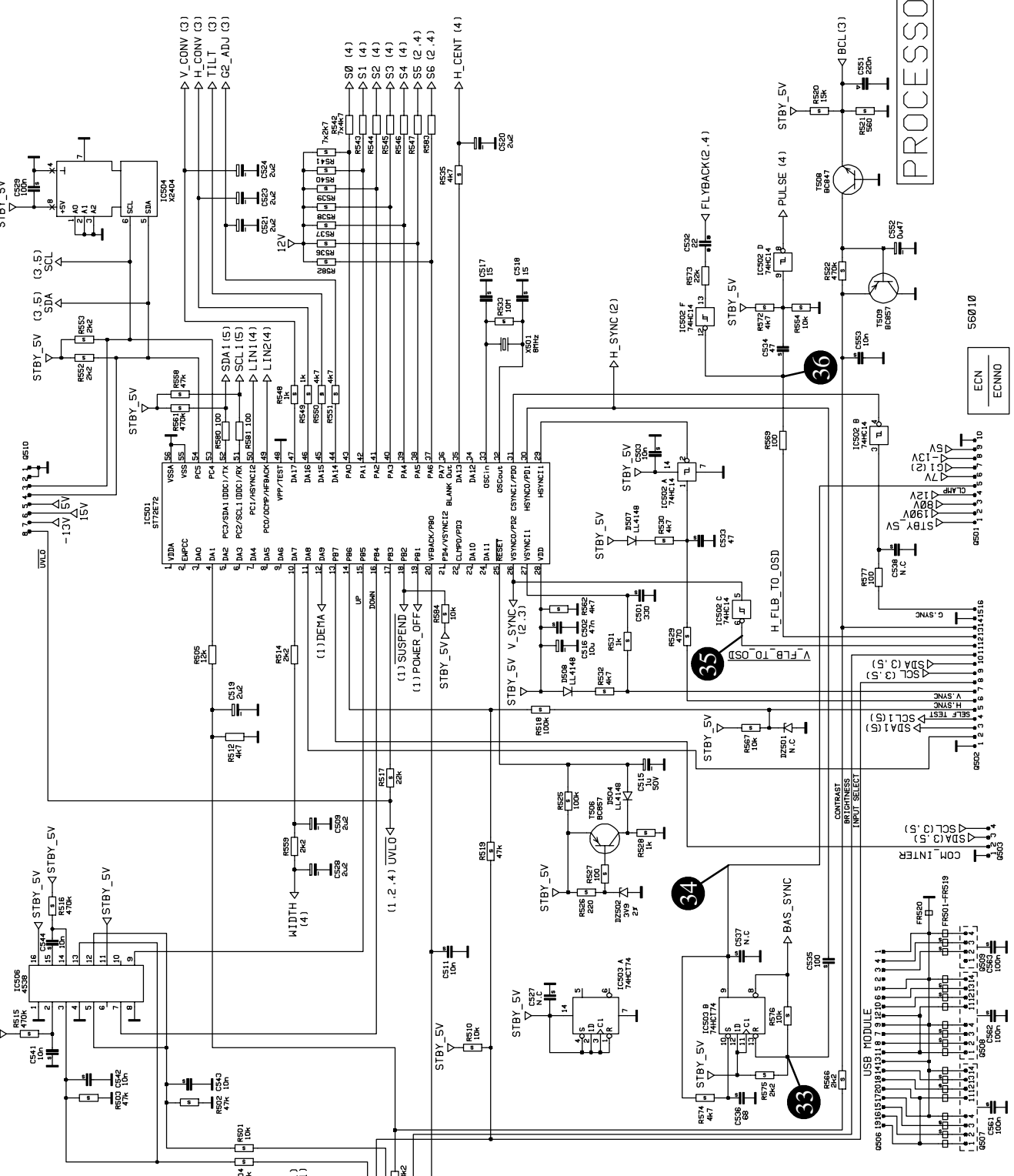

Symbol	Material	Value	Notes
	CERAMIC	< 63 V	
	POLYPROPYLENE	< 63 V	
	POLYESTHER	< 63 V	
		< 160 V	
		< 250 V	
		< 300 V	
		< 1.5 kV	

SMA193E



D3122E 05.97 Page 54

445T

CAUTION: FOR CONTINUED PROTECTION AGAINST FIRE
HAZARD REPLACE FUSE ONLY WITH SAME TYPE AND RATING

