

Part Number	Description	PG	Item Number
AC4441	CHIPRES 0W1 47R 5% 0805 2013	01	RZ 002 003 004
AC4473	CHIPRES 0W1 1K0 5% 0805 2013	01	RZ 001
AC4513	CHIPRES 0W1 47K 5% 0805 2013	01	RZ 005
CB3141	CHIPCERCAP NP0 47P 50V J 0805	01	CZ 002 003 004
CC4440	CHIPCAP X7R 100N K 50V 1206	02	CZ 001
JH4109	ZDI BZX84C5V1 5.1V 0.35W 5%	03	DZZ 001
JH4110	ZDI BZX84 C5V6 SOT23	02	DZZ 002 003
LM4420	IC DUAL MODE EEPROM FOR DDC 2.0	02	ICZ 002
QK1707	PICOFLEX HEADER 1X16 1,27MM	04	QZ 002
QK1718	FEMALE ON BOARD 2X8POS 1,27MM	07	QZ 001
AA0625	CF RES 0W25 10R J 2,5-7	01	RA 216
AA0641	CF RES 0W25 47R J 2,5-7	01	RA 091
AA0649	CF RES 0W25 100R J 2,5-7	01	RA 305 321 422 525 561 601
AA0657	CF RES 0W25 220R J 2,5-7	01	RA 085 317 322 407
AA0661	CF RES 0W25 330R J 2,5-7	01	RA 127
AA0665	CF RES 0W25 470R J 2,5-7	01	RA 343
AA0667	CF RES 0W25 560R J 2,5-7	01	RA 432
AA0673	CF RES 0W25 1K0 J 2,5-7	01	RA 140 223 261 526 531 536 374 377 378
AA0677	CF RES 0W25 1K5 J 2,5-7	01	RA 433 458
AA0681	CF RES 0W25 2K2 J 2,5-7	01	RA 107 559
AA0683	CF RES 0W25 2K7 J 2,5-7	01	RA 455
AA0687	CF RES 0W25 3K9 J 2,5-7	01	RA 425
AA0689	CF RES 0W25 4K7 J 2,5-7	01	RA 228 304 510 518 519
AA0697	CF RES 0W25 10K J 2,5-7	01	RA 191 237 311 399 462 557
AA0699	CF RES 0W25 12K J 2,5-7	01	RA 387
AA0701	CF RES 0W25 15K J 2,5-7	01	RA 406 453 568
AA0705	CF RES 0W25 22K J 2,5-7	01	RA 121 452 456 580
AA0709	CF RES 0W25 33K J 2,5-7	01	RA 211
AA0713	CF RES 0W25 47K J 2,5-7	01	RA 507 520 521 522 382
AA0721	CF RES 0W25 100K J 2,5-7	01	RA 442
AA0725	CF RES 0W25 150K J 2,5-7	01	RA 324
AA0729	CF RES 0W25 220K J 2,5-7	01	RA 345 414
AA0741	4F RES 0W25 680K J 2,5-7	01	RA 459
AA0752	*EKU*CF RES 0W25 1M8 J 2,5-7	01	RA 333
AA0761	CF RES 0W25 4M7 J 2,5-7	01	RA 100 102
AB0601	NF RES 0W25 1R0 J 2,5-7 CF	01	RA 159 162 411
AB0605	NF RES 0W25 1R5 J 2,5-7 CF !	01	RA 281
AB0609	NF RES 0W25 2R2 J 2,5-7 CF	01	RA 334
AB0613	NF RES 0W25 3R3 J 2,5-7 CF	01	RA 369
AB0617	NF RES 0W25 4R7 J 2,5-7 CF	01	RA 417
AB0625	NF RES 0W25 10R J 2,5-7 CF	01	RA 110 222
AB0629	NF RES 0W25 15R J 2,5-7 CF	01	RA 361
AB0649	NF RES 0W25 100R J 2,5-7 CF	01	RA 350
AB0785	NF RES 0W5 0R22 J 4-11 CF	02	RA 318 167
AB0795	NF RES 0W5 0R56 J 4-11 CF	02	RA 133 134
AB0801	NF RES 0W5 1R0 J 4-11 CF	02	RA 424
AB0841	NF RES 0W5 47R J 4-11 CF	01	RA 155
AC3332	CHIPRES 2K61 0W1 1% 0805	01	RA 206
AC3349	CHIPRES 3K92 0W1 1% 0805	01	RA 205
AC3421	CHIPRES 22K1 0W1 1% 0805	01	RA 582 585 588
AC3453	CHIPRES 47K5 0W1 1% 0805	01	RA 591 592 593
AC3559	CHIPRES 0W1 39K0 1% 0805 2013	01	RA 583 586 589
AC4400	CHIPRES 0W1 0R0 5% 0805 2013	01	JA 402 461 702 703 705 706 707 708
AC4417	CHIPRES 0W1 4R7 5% 0805 2013	01	RA 278
AC4425	CHIPRES 0W1 10R 5% 0805 2013	01	RA 128 408 410 440
AC4429	CHIPRES 0W1 15R 5% 0805 2013	01	RA 129
AC4433	CHIPRES 0W1 22R 5% 0805 2013	01	RA 309 310 316
AC4441	CHIPRES 0W1 47R 5% 0805 2013	01	RA 571 572
AC4443	CHIPRES 0W1 56R 5% 0805 2013	01	RA 366
AC4449	CHIPRES 0W1 100R 5% 0805 2013	01	RA 388 418 445 446 447 448 449
AC4457	CHIPRES 0W1 220R 5% 0805 2013	01	RA 132 225
AC4465	CHIPRES 0W1 470R 5% 0805 2013	01	RA 139 150 190 192 193 423 427 529
AC4469	CHIPRES 0W1 680R 5% 0805 2013	01	RA 573
AC4473	CHIPRES 0W1 1K0 5% 0805 2013	01	RA 105 131 144 210 260 370 371 380 381 404 419 421
AC4473	CHIPRES 0W1 1K0 5% 0805 2013	01	RA 509 517 524 555
AC4475	CHIPRES 0W1 1K2 5% 0805 2013	01	RA 209
AC4477	CHIPRES 0W1 1K5 5% 0805 2013	01	RA 413 365
AC4479	CHIPRES 0W1 1K8 5% 0805 2013	01	RA 217
AC4481	CHIPRES 0W1 2K2 5% 0805 2013	01	RA 123 124 306 314 320 327 346 364 514 576
AC4483	CHIPRES 0W1 2K7 5% 0805 2013	01	RA 108 145 537 538 539 540 541
AC4489	CHIPRES 0W1 4K7 5% 0805 2013	01	RA 202 213 249 303 313 389 409 416
AC4489	CHIPRES 0W1 4K7 5% 0805 2013	01	RA 441 457 508 511 512 513 515 516 523
AC4489	CHIPRES 0W1 4K7 5% 0805 2013	01	RA 535 542 543 544 545 546 548 549
AC4489	CHIPRES 0W1 4K7 5% 0805 2013	01	RA 550 551 562 597
AC4491	CHIPRES 0W1 5K6 5% 0805 2013	01	RA 244 245 246 252 253 363
AC4493	CHIPRES 0W1 6K8 5% 0805 2013	01	RA 106
AC4497	CHIPRES 0W1 10K 5% 0805 2013	01	RA 125 130 141 146 212 219 224 234 247 248 263
AC4497	CHIPRES 0W1 10K 5% 0805 2013	01	RA 301 302 329 330 331 335 362 367 373 375 376
AC4497	CHIPRES 0W1 10K 5% 0805 2013	01	RA 403 527 530 532 556 577
AC4499	CHIPRES 0W1 12K 5% 0805 2013	01	RA 208 214
AC4501	CHIPRES 0W1 15K 5% 0805 2013	01	RA 220 415
AC4505	CHIPRES 0W1 22K 5% 0805 2013	01	RA 326 451 598
AC4507	CHIPRES 0W1 27K 5% 0805 2013	01	RA 122 240 241 242 243 255 256 257 259
AC4509	CHIPRES 0W1 33K 5% 0805 2013	01	RA 171 402 595
AC4513	CHIPRES 0W1 47K 5% 0805 2013	01	RA 215 221 239 379 393 547
AC4515	CHIPRES 0W1 56K 5% 0805 2013	01	RA 148 218
AC4517	CHIPRES 0W1 68K 5% 0805 2013	01	RA 258 401
AC4519	CHIPRES 0W1 82K 5% 0805 2013	01	RA 254

Part Number	Description	PG	Item Number
AC4521	CHIPRES 0W1 100K 5% 0805 2013	01	RA 094 460 554 594
AC4525	CHIPRES 0W1 150K 5% 0805 2013	01	RA 584 587 590
AC4529	CHIPRES 0W1 220K 5% 0805 2013	01	RA 251 262 348
AC4535	CHIPRES 0W1 390K 5% 0805 2013	01	RA 250
AC4537	CHIPRES 0W1 470K 5% 0805 2013	01	RA 319 394 596
AC4545	CHIPRES 0W1 1M0 5% 0805 2013	01	RA 528 560
AC4551	CHIPRES 0W1 1M8 5% 0805 2013	01	RA 325
AC4561	CHIPRES 0W1 4M7 5% 0805 2013	01	RA 143
AC4569	CHIPRES 0W1 10M 5% 0805 2013	01	RA 533
AD0373	COMPRES 0W5 1K0 K 4-11	01	RA 332
AD0445	COMPRES 0W5 1M0 K 4-11	01	RA 101
AG3119	MF RES 0W5 1R54 F TC200 2,5-7	01	RA 279
AG3233	MF RES 0W5 21R5 F TC50 2,5-7	01	RA 437
AG3251	MF RES 0W5 33R2 F TC50 2,5-7	01	RA 087
AG3265	MF RES 0W5 46R4 F TC50 2,5-7	01	RA 163 164 168 347 430
AG3301	MF RES 0W5 100R F TC50 2,5-7	01	RA 315
AG3319	MF RES 0W5 154R F TC50 2,5-7	01	RA 086
AG3343	MF RES 0W5 274R F TC50 2,5-7	01	RA 280
AG3365	MF RES 0W5 464R F TC50 2,5-7	01	RA 142 161
AG3373	MF RES 0W5 562R F TC50 2,5-7	01	RA 147
AG3433	MF RES 0W5 2K15 F TC50 2,5-7	01	RA 149 199 344
AG3443	MF RES 0W5 2K74 F TC50 2,5-7	01	RA 154
AG3473	MF RES 0W5 5K62 F TC50 2,5-7	01	RA 126 420
AG3481	MF RES 0W5 6K81 F TC50 2,5-7	01	RA 272 277
AG3489	MF RES 0W5 8K25 F TC50 2,5-7	01	RA 307
AG3501	MF RES 0W5 10K0 F TC50 2,5-7	01	RA 152 368
AG3509	MF RES 0W5 12K1 F TC50 2,5-7	03	RA 270 271 349
AG3519	MF RES 0W5 15K4 F TC50 2,5-7	01	RA 575
AG3525	MF RES 0W5 17K8 F TC50 2,5-7	01	RA 574
AG3543	MF RES 0W5 27K4 F TC50 2,5-7	01	RA 308
AG3551	MF RES 0W5 33K2 F TC50 2,5-7	01	RA 390
AG3557	MF RES 0W5 38K3 F TC50 2,5-7	01	RA 114 117 120 431 434
AG3589	MF RES 0W5 82K5 F TC50 2,5-7	01	RA 405
AG3609	MF RES 0W5 121K F TC50 2,5-7	01	RA 153
AG3619	MF RES 0W5 154K F TC50 2,5-7	01	RA 119 323
AG3633	MF RES 0W5 215K F TC50 2,5-7	01	RA 170
AG3651	MF RES 0W5 332K F TC50 2,5-7	01	RA 115 116
AG3657	MF RES 0W5 383K F TC50 2,5-7	01	RA 412
AG3665	MF RES 0W5 464K F TC50 2,5-7	01	RA 385
AJ2323	MO RES 2W0 1R5 J 6-17	01	RA 372
AJ2463	MO RES 2W0 5R6 J 6-17	02	RA 088 089 090
AJ2703	MO RES 2W0 56R J 6-17	02	RA 428 429
AJ2763	MO RES 2W0 100R J 6-17	02	RA 426 438
AJ2923	MO RES 2W0 470R J 6-17	02	RA 136
AJ3003	MO RES 2W0 1K0 J 6-17	02	RA 157 158
AJ3103	MO RES 2W0 2K7 J 6-17	02	RA 436
AJ3483	MO RES 2W0 100K J 6-17	02	RA 156
AJ3385	MO RES 4W0 39K J 9-22	03	RA 137
AP1103	DOUBLE FOCUS POT.MET.BLOCK 447Z	24	FOCA 301
AQ2219	TPMET.AA H10 47K RM 5X10 6-HOLE	03	RTA 301 401
AQ2745	TPMET.AA V10 10K RM5X2,5 6-HOLE	01	RTA 402
AW0079	PTC-THERMISTOR 18R/25°C RM5	07	PTCA 001 002
AW0111	NTC-THERMISTOR 5R0/25°C RM5+2,5	07	NTCA 001
CB0658	CERCAP N750 82P J 500V Y5: D9	01	CA 416
CB3129	CHIPCERCAP NP0 15P 50V J 0805	03	CA 517 518
CB3141	CHIPCERCAP NP0 47P 50V J 0805	01	CA 237 238 339 525
CB3145	CHIPCERCAP NP0 68P 50V J 0805	01	CA 302
CB3151	CHIPCERCAP NP0 100P 50V J 0805	01	CA 301 303 313 406 407 444
CB3163	CHIPCERCAP NP0 330P 50V J 0805	01	CA 128 314
CB3167	CHIPCERCAP NP0 470P 50V J 0805	02	CA 446
CB3171	CHIPCERCAP NP0 680P 50V J 0805	01	CA 212
CB3175	CHIPCERCAP NP0 1N0 50V J 0805	03	CA 156 242 308 315 537 539
CC0110	CERCAP Y5P 150P K 500V Y5: D8	01	CA 418 419
CC0130	CERCAP Y5P 220P K 500V Y5: D8	01	CA 328 445
CC0170	CERCAP Y5P 470P K 500V Y5: D8	01	CA 149 172
CC0200	CERCAP Y5P 1N0 K 500V Y5: D9	01	CA 137 147 159 438 542
CC0240	CERCAP Y5P 2N2 K 500V Y5: D9	01	CA 120 318 420
CC0513	CERCAP Y5V 3N3 S 1KV Y7,5 D14	02	CA 107 109
CC0530	CERCAP Z5U 4N7 S 500V Y5: D9	01	CA 311 412 437
CC3240	CHIPCERCAP X7R 2N2 10% 50V 0805	01	CA 346 347
CC3280	CHIPCERCAP X7R 4N7 10% 50V 0805	01	CA 129 234 325 338
CC3320	CHIPCERCAP X7R 10N 10% 50V 0805	01	CA 127 131 155 202 205 214 219 220
CC3320	CHIPCERCAP X7R 10N 10% 50V 0805	01	CA 221 222 223 224 304 329 404 442 532
CC3320	CHIPCERCAP X7R 10N 10% 50V 0805	01	CA 533 534 538
CC3300	CHIPCERCAP X7R 6N8 10% 50V 0805	01	CA 355 356
CC3360	CHIPCERCAP X7R 22N 10% 50V 0805	01	CA 530 343
CC3380	CHIPCERCAP X7R 33N 10% 50V 0805	01	CA 236
CC4320	CHIPCAP X7R 10N K 50V 1206	02	CA 204
CC4400	CHIPCAP X7R 47N K 50V 1206	02	CA 122 168 209 210 211 216 227 529
CC4855	CHIPCAP Y5V 100N Z 50V 1206	03	CA 316 326 333 342 345 348 351 402 414 432
CC4855	CHIPCAP Y5V 100N Z 50V 1206	03	CA 433 434 435 436 515 535 536 601 602 603
CE0084	X2-CAP 220N M 275VAC Y22,5 PLAST.	01	CA 102
CE0116	Y-CAP 2N2 M 400VAC Y12,5 SDPJ16	04	CA 101 103 112
CE2004	IMPCAP 100P K 1K6V Y15 051118	03	CA 119
CE2034	IMPCAP 270P K 1K5V Y15 051118	04	CA 146
CE2234	IMPCAP 3N3 K 1K5V Y22,5 081628	04	CA 307
CE2256	IMPCAP 3N9 J 2KV Y22,5 111927	04	CA 413
CE2850	IMPCAP 68N J 250V Y10 SING.MET	04	CA 415

Part Number	Description	PG	Item Number
CE2930	IMPCAP 100N J 250V Y10 SING.MET	03	CA 427
CE2960	IMPCAP 150N J 250V Y15 SING.MET	03	CA 428
CE3040	IMPCAP 270N J 250V Y15 SING.MET	04	CA 421
CE3060	IMPCAP 330N J 250V Y15 SING.MET	04	CA 429
CE3170	IMPCAP 800N J 160V Y22,5 SING.MET	06	CA 430
CG2344	PPRCAP KP 220P H 63V Y5: 050608	02	CA 403
CG2717	PPRCAP KP 10N H 63V Y5: 060808	03	CA 126
CK0165	PESCAP MKT 22N K 630V Y10 061213	02	CA 117 118 408
CK0341	PESCAP MKT 220N K 100V Y10 051113	03	CA 233
CK0342	PESCAP MKT 220N K 250V Y5 080814	03	CA 411
CK1388	PESCAP MKT 10N K 250V Y7,5 040911	02	CA 305
CK1389	PESCAP MKT 10N K 400V Y7,5 040911	02	CA 140
CK1468	PESCAP MKT 22N K 250V Y7,5 051011	02	CA 143
CK2464	PESCAP MKT 22N K 63V Y5: 030708	02	CA 206
CK2464	PESCAP MKT 22N K 63V Y5: 030708	02	CA 410
CK2544	PESCAP MKT 47N K 63V Y5: 030708	02	CA 312 324
CK2584	PESCAP MKT 68N K 63V Y5: 030708	02	CA 353 354
CK2626	PESCAP MKT 100N K 63V Y5: 030808	02	CA 138
CK2663	PESCAP MKT 150N J 63V Y5: 040908	03	CA 225
CK2704	PESCAP MKT 220N K 63V Y5: 040908	03	CA 310
CK2784	PESCAP MKT 470N K 63V Y5: 051008	03	CA 228
CN0088	ELCAP 220U M 385V R10 85' 26X52	18	CA 110
CN0126	ELCAP 0U47 M 50V RM5 : 6*12	01	CA 213 309 336
CN0204	ELCAP 2U2 M 50V RM5 : 6*12	01	CA 136 201 235 443 447 503 504 505 506 507
CN0204	ELCAP 2U2 M 50V RM5 : 6*12	01	CA 508 509 510 511 512 513 520 521 522 523
CN0204	ELCAP 2U2 M 50V RM5 : 6*12	01	CA 524 528
CN0308	ELCAP 10U M 50V RM5 : 6*12	01	CA 344 349 405 514 516 526
CN0519	ELCAP 220U M 16V RM5 : 9*14	02	CA 341
CN0423	ELCAP 47U M 50V RM5 : 9*13	02	CA 152 208 226 358
CN0817	ELCAP 2200U M 25V RM7,5 17X33	05	CA 150
CN2017	ELCAP 1U0 M 50V RM5: 105' 6X12	02	CA 115 124 125 158 317 327
CN2228	ELCAP 4U7 M 200V RM5 105' 10X12,5	05	CA 440
CN2467	ELCAP 47U M 200V RM5 105'14X27	05	CA 141 142 144 439
CN2523	ELCAP 100U M 25V RM5 :105' 9*14	03	CA 145 215 359 401
CN2539	ELCAP 100U M 50V RM5 : 9*14	03	CA 230
CN2566	ELCAP 4U7F M 50V RM5: 105'6X12MM	02	CA 151 154 203
CN2581	ELCAP 220U M 35V RM5 105 11X13	03	CA 121
CN2581	ELCAP 220U M 35V RM5 105 11X13	03	CA 166
CN2581	ELCAP 220U M 35V RM5 105 11X13	03	CA 229 231
CN2711	ELCAP 1000U M 16V RM5: 11X21	03	CA 350
CN2712	ELCAP 1000U M 16V RM5: 105'11X21	05	CA 148
CN2716	ELCAP 1000U M 35V RM5: 105'14X26	09	CA 160
FA4000	CHIP INDUCTOR 600OHM 200MA 0805	01	FRA 602 603 606 607 610 611 614 615 618 619
FJ0448	CHOKE 13UH FERRITE 2X15	02	LA 104
FJ0505	CHOKE 15UH 5% TAPED AXIAL	02	LA 409
FJ0516	CHOKE 1MH 5% TAPED AXIAL	02	LA 405 408
FJ0725	BEAD INDUCTOR MIN IMP360HM	02	FRA 401 601 604 605 608 609 612 613 616 617 620
FJ0735	LEAD INDUCTOR 82UH 10% Y=5MM	07	LA 407
FJ0800	EMI/RFI CHOKE 60MH 3A(AC)	14	MA 101
FJ1827	INPUT CHOKE E25/7 2X6.9MH	11	MA 104
FM0631	FLYBACK TRAF0 30..72KHZ W/O FOC Z	30	MA 301
FM2503	INPUT COIL E20/6 1M4H	15	MA 404
FM2552	DRIVER TRAF0 E20/6 449M	12	MA 401
FM2554	CENTERING COIL E20/6 2.25MH 449J	12	MA 402
FM2560	DYNAMIC FOCUS TRAF0 E20/6 445R	12	MA 403
FM3906	SMPS-TRAF0 ETD39 447Z	16	MA 103
FU0718	FIXED LINEARITY COIL 447Z	12	LA 403
JB0047	DI GP30M 1000V 3A 3,0US DO201AD	04	DA 101 102 103 104
JF0025	DI 1N4148 75V 200MA 4N	01	DA 108 123 126 145 209 302 316 401 416 418
JF0025	DI 1N4148 75V 200MA 4N	01	DA 427 507
JF0032	DI UF4007 1000V 1A 75N DO41/SOD57	04	DA 112
JF0034	DI UF5406 600V 3A 75N	09	DA 306
JF0060	DI 1N4002 100V 1A	01	DA 138 207
JF0062	DI BA159 1000V 400MA 500N	02	DA 426
JF0072	DI BAV21 200V 250MA 50N	01	DA 106
JF0073	DI RGP10G 400V 1A 150N	02	DA 412 414 419 420 421 422 428
JF0074	DI RGP15J 600V 1.5A 250N	04	DA 124
JF0107	DI BYV26C 600V 1A 30N	05	DA 127 128
JF0165	DIODE BY359 1500V 5A FULLISOL.	13	DA 410
JF0168	DIODE BYW98-200 200V 3A DO-27A !	04	DA 129 133 404
JF4003	DI BAV103 200V 250MA 50NS SOD-80	07	DA 105 423
JF4005	DI LL4148 75V 150MA 4N (JF4006)	01	DA 107 120 121 122
JF4005	DI LL4148 75V 150MA 4N (JF4006)	01	DA 201
JF4005	DI LL4148 75V 150MA 4N (JF4006)	01	DA 204 205 208 301 303 304 305 307 315
JF4005	DI LL4148 75V 150MA 4N (JF4006)	01	DA 317 318 402 403 405 406 407 408 415 504
JF4005	DI LL4148 75V 150MA 4N (JF4006)	01	DA 506 508 515 516
JF4011	SCHOTTKY BARRIER 30V 200MA SOT-23	03	DA 202
JH0053	ZDI BZX83C5V6 5.6V 0.5W 5%	01	DZA 501 502
JH0054	ZDI BZX83C12 12V 0.5W 5%	01	DZA 107 108 109 301 401 403
JH0090	ZDI BZX79B9V1 9.1V 0.5W 2%	03	DZA 104
JH0169	ZDI BZX55B3V9 3.9V 0.5W 2%	03	DZA 303
JL0069	OPTOCOUPLER VRMS 5KV	04	ICA 102 107 302
JM0099	TR BC547B N 45V 100A 200M:	01	TA 301 305 307
JM0100	TR BC557B P 45V 100A 200M:	01	TA 302 306 425
JM0205	TR BF423 P 250V 25MA 60M:	03	TA 110 404
JM0205	TR BF423 P 250V 25MA 60M:	03	TA 314
JM0244	TR BF422 N 250V 25MA 60M:	02	TA 103 104 311 315 408 412 413
JM0252	TR BC639-10 N 100V 1.5A TO92	03	TA 406

Part Number	Description	PG	Item Number
JM0252	TR BC639-10 N 100V 1.5A TO92	03	TA 421
JM0253	TR MPS2222A N 40V 600MA 300M	03	TA 316
JM0273	TR 2N5551 NPN 160V 0,6A	02	TA 206 312 313
JM0280	TR 2N5401 P 150V 0.6A 100M	02	TA 409
JM0281	TR BC368 N 20V 1A 60M:	04	TA 122
JM0314	TR BU2522AF N 1500V 8A SOT199	14	TA 407
JM4105	TR BC847B N 45V 0.1A SOT23	04	TA 105 121 124 309 318 401 402 422
JM4114	TR BC857B P 45V 100MA 150M:	02	TA 106 202 308 317 403 423 507
JM4401	TR BCR141W 50V 0.1A (2X22K)SOT323	02	TA 120 126
JS0016	FET SSP6N60 N 600V 6.A 1R2 TO220	11	TA 107
JS0033	FET IRFD014 N 60V 1.7A HD-1	07	TA 108
JS0035	FET IRF820 N 500V 2.5A 3.0R	10	TA 411
JS0058	FET IRF9620 P 200V 1R5 3A TO220FI	10	TA 303
JS0058	FET IRF9620 P 200V 1R5 3A TO220FI	10	TA 405
JS0063	FET IRFIBE30G N 800V 2,1A 3R0 220	23	TA 304
JS0068	FET IRFI520G N 100V 7.0A 0.27R	07	TA 127 428 429
JS0069	FET IRFI530G N 100V 9.0A 0.16R	08	TA 427
JS0069	FET IRFI530G N 100V 9.0A 0.16R	08	TA 426
JS1006	FET BS170 N 60V 500MA	10	TA 111
JZ0005	SILICONE INSUL. PAD 19*13*0.22MM	01	ICA 203
JZ0005	SILICONE INSUL. PAD 19*13*0.22MM	01	T 107
LM0067	IC UA7805UC +5V REGULATOR TO-220	13	ICA 111
LM0547	IC TDA1013B AUDIO POWER AMPL SIL9	11	ICA 305
LM0602	IC LM2940CT-12 +12V REGULATOR	12	ICA 104
LM0927	IC TDA7057AQ AUDIO AMP. 2X3W 13PIN	14	ICA 306
LM0937	IC TDA9105 DEFLECTION PROCESSOR	20	ICA 201
LM0938	IC ST72E72 MONITOR UC,DDC DIP-56	34	ICA 501
LM0942	IC TL431 VOLTAGE REFERENCE TO-92	04	TA 109 506
LM0951	IC LM78L05A VOLTAGE REGUL.5V TO92	04	ICA 103
LM0956	IC TDA9309 VERT.DEFL.BOOSTER HWAT	08	ICA 203
LM0959	IC L4990 PRIMARY CONTROLLER DIP16	10	ICA 101
LM4017	IC 74HCT02 QUAD 2-INPUT NOR SO-14	04	ICA 502
LM4111	IC 4538BT	05	ICA 301 401
LM4406	IC LM324 QUAD OP-AMP SO-14	05	ICA 304
LZ0063	IC-SOCKET 56-POLE DUAL LEAF 1.78	10	ICA 501
QA0095	CRYSTAL 8,00 MHZ HC-49/U	04	XA 501
QH0068	RELAY PCB-MOUNT 12V 5A/250V DPDT	13	REA 101
QK0851	TAP CONN RTM 1,3/5/8.002	01	QA 402
QK1225	ROW CONN 1X05 2,5 VERT STG LOCK	02	QA 605
QK1281	ROW CONN 1X02 7,62 VER/LOCK W/SNP	03	QA 102 301
QK1287	PIN STRIP 1X04 8,0/10.0 VERT MALE	03	QA 401
QK1294	PIN JACK (RCA) FEMALE BCB RED 90	04	QA 308
QK1295	PIN JACK (RCA) FEMALE BCB WHI 90	04	QA 309
QK1415	CRIPLET CONN FOR 2-SIDED PCB	01	
QK1587	COOLING & SUPP.PART FOR RESISTOR	01	RA 137
QK1599	COOLING & SUPP.PART FOR RES L12MM	01	NTCA 001
QK1633	ROW CONN 1X03 2,5V STGLOCK SNAP	02	QA 310
QK1635	ROW CONN 1X05 2,5V STGLOCK SNAP	02	QA 305
QK1650	MAINS CONN MALE 90DEG W/PCB SNAPS	08	QA 101
QK1675	SOLDER SUPPORT FOR CABLE 2-POS	02	QA 311 312
QK1702	PICOFLEX HEADER 1X06 1,27MM	03	QA 304
QK1712	PIN JACK 3,6MM MONO H=6,5MM	03	QA 307
QK1713	USB CONN SERIE-A DOUPLE STACKED	04	QA 601 602
QK1714	USB CONN SERIE-B	04	QA 603
QK1717	SOLDER SUPPORT FOR CABLE 3-POS	05	QA 201 202
QK1719	MALE ON BOARD 2X8POS 1,27MM	07	QA 501
QM0298	SIGNAL CABLE VGA-49 447Z	24	
QM1025	PICOFLEX ASSY BI-IDC 6-POS 250MM	07	QA 503
QM1026	PICOFLEX ASSY IDC-IDC 16POS 450MM	10	QZ 001
QT0004	SPARK GAP 2,5KV +-500V R=5,0MM	05	GLA 303
QT0102	FUSEHOLDER CLIPS 5*20MM R=5,0MM	01	FA 101
QT0217	GLIMM LAMP 65V 6*16MM	03	GLA 301 302 304
QT0733	FUSE R=5,0MM T 3,15A 250V IEC127	04	FA 102
QT0775	FUSE 5*20MM T 6,3A 250V 1500A	03	FA 101
XS0094	WIRE TINNED COPPER D=0,60MM	21	
SE2185	GROUNING CABLE 7752	06	WA 101
QK1035	CABLE SHOE 160101-2	02	
QK1446	WIRE TERMINAL FOR 1,85MM HOLES	01	
XS0461	WIRE STRAN 34/0,18MM UL1007 G/Y	04	
SE2679	GROUNING CABLE 447S	04	WA 301
QK1446	WIRE TERMINAL FOR 1,85MM HOLES	01	003
QK1651	"BLADE CONNECTOR ""MIKROLOK"" 6,3MM"	01	002
XS0465	WIRE STRAN 34/0,18MM UL1007 BLACK	03	001
SE2687	FLATCABLE VERTIKAALI 3-POLE 447Z	03	QA 201 202
XS0474	BAND CABLE STRAN 3-POLE R=2,50	04	
SE2693	FOCUSWIRE 447Z	03	
XS1040	HVWIRE 20KV SOLID UL3239 BLA 105'	04	001
SE2694	FOCUSWIRE 447Z	03	
XS0903	HVWIRE 20KV SOLID UL3239 RED 105'	04	001
SE2695	G2-WIRE 447Z	05	
QK1576	SOCKET CONTACT FOR 2.36MM PIN	01	002
QK1577	HOUSING FOR 2.36MM DIA.PIN RECEPT	03	003
XS1041	WIRE SOLID 0,81MM UL1032 1K2V 90'	03	001
UC0859	FASTENING SPRING PN44473	02	TA 303 304 405
UC0859	FASTENING SPRING PN44473	02	ICA 104 111
UC1140	J_HDYTYSLEVY/COOLING PLATE KUPAR	02	TA 304 405

Part Number	Description	PG	Item Number
UC1140	J_HDYTYSLEVY/COOLING PLATE UPAR	02	ICA 104 111
XE0057	CU-FLATCABLE 0,5*50MM	22	
UC2420	J_HDYTYSLEVY/COOLING PLATE PN302231	08	TA 303
XE0107	CU-FLATCABLE 0.5X80.0MM	01	
UC6551	KIINNITYSJOUSI/FASTENING SPRING	03	ICA 203
UC6551	KIINNITYSJOUSI/FASTENING SPRING	03	DA 410
UC6551	KIINNITYSJOUSI/FASTENING SPRING	03	TA 107 426
UC6552	KIINNITYSJOUSI/FASTENING SPRING	03	TA 407
UC6552	KIINNITYSJOUSI/FASTENING SPRING	03	ICA 306
UC675	WASHER 447E	01	
XE0110	TINNED STEEL STRIP 0,8 X 19.1MM	01	
UC6801	STRAIN RELIEF 447E	08	
UC6859	J_HDYTYSLEVY/COOLING PLATE 447S	09	TA 407 426
UC6859	J_HDYTYSLEVY/COOLING PLATE 447S	09	DA 410
UC6863	LIITINPANEELI/CONNECT.PANEL 447S	08	
UC6864	TUKI/SUPPORT 447S	04	
UC6865	ETUTUKI/FRONT SUPPORT 447S	04	
UCX012	DIODI/J_HDL.KOK.PANO JF0166	05	DA 125
JF0166	DIODE BYM26C 600V 2.3A SOD-64	06	
UCX015	DIODI/J_HDL.KOK.PANO JF0168	05	DA 130
JF0168	DIODE BYW98-200 200V 3A DO-27A !	04	
UCX016	UC6860+UC6861+UG1001+WC0450	13	
UC6860	J_HDYTYSLEVY/COOLING PLATE 447S	08	
UC6861	J_HDYTYSLEVY/COOLING PLATE 447S	09	
WC0450	KKL HEXAGON+TORX10 3,9X16 ZN	01	
UG1001	INSULATOR GROMMET EG-3-71	03	
UG0699	SUPPORT GRID TUKIRISTIKKO PN10121	10	
UG0770	JOHTOPIDIKE SIS. MITAT 11X20MM	05	
UG0812	INSULATOR PN30068 445R	04	
UG0814	INSULATOR PN30084 447K	06	
UG1007	SHIELD PN30163 447Z	02	
UG1012	TUKI/SUPPORT PN20117 447Z	02	
WA0749	M4X8 DIN962 DIN269 8.8	01	
WC0036	KUUS.KAN.LEVYR.UNI6950 SCREW	01	
WC0353	PT-SCR KB 40X10 WN1447 FE/ZN YELL	01	
WC0446	KUUS.KANT.-TYLPP_ 2,9X8 SCREW FE/ZN	01	
WC0450	KKL HEXAGON+TORX10 3,9X16 ZN	02	
WL0217	WASHER 4,3 ST DIN6798A	01	
XW0032	L_MP.JOHT.RASVA DOW CORNING	03	DA 410
XW0032	L_MP.JOHT.RASVA DOW CORNING	03	TA 407

	CERAMIC	POLYPROPYLENE	POLYESTHER POLYCARBONATE
	$\leq 63 \text{ V}$	$\leq 63 \text{ V}$	$\leq 63 \text{ V}$
	$\leq 160 \text{ V}$	$\leq 160 \text{ V}$	$\leq 160 \text{ V}$
	$\leq 250 \text{ V}$	$\leq 250 \text{ V}$	$\leq 250 \text{ V}$
	$\leq 500 \text{ V}$	$\leq 500 \text{ V}$	$\leq 500 \text{ V}$
	$\leq 1,5 \text{ kV}$	$\leq 1,5 \text{ kV}$	$\leq 1,5 \text{ kV}$

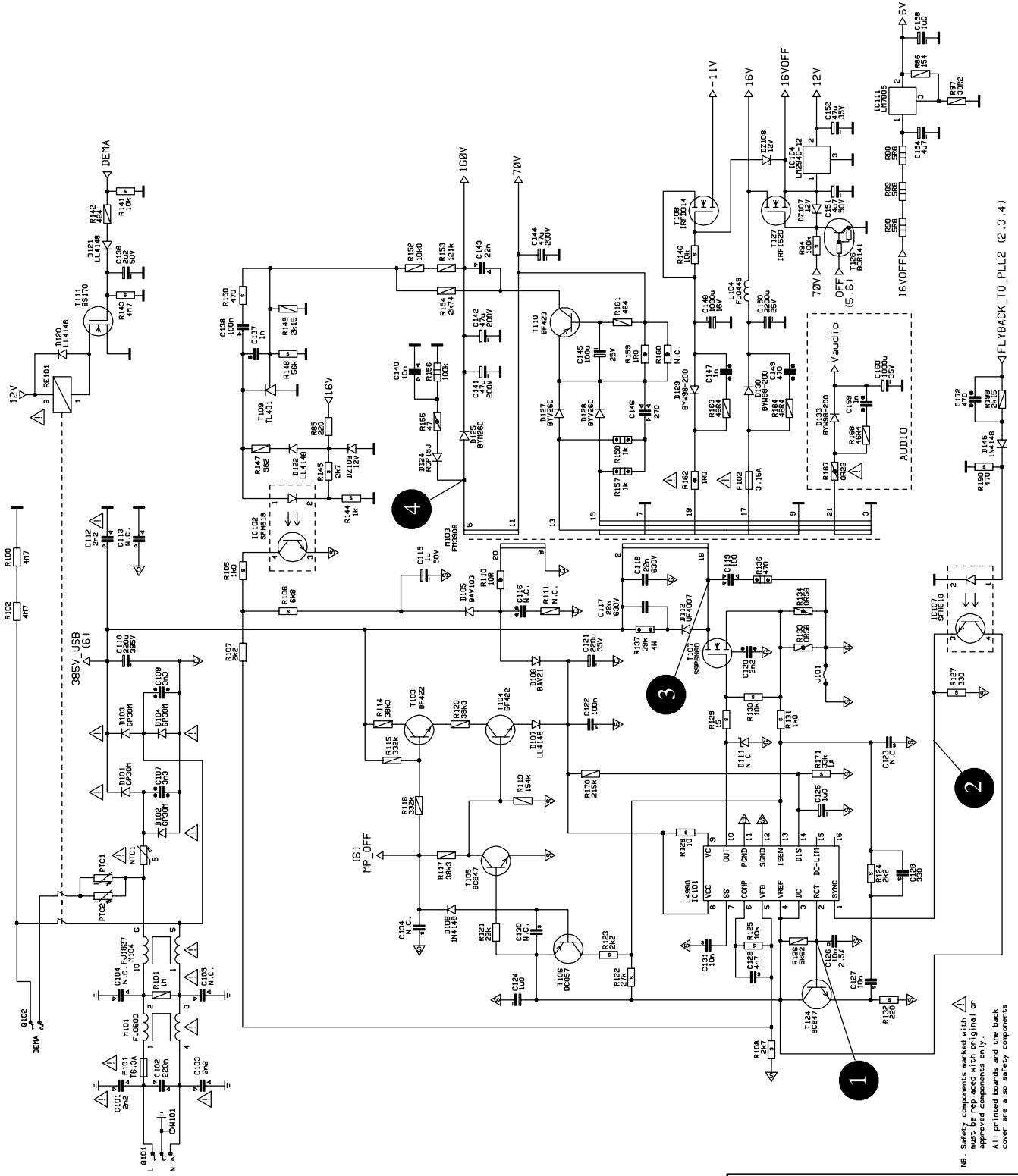

POWER SUPPLY

56009D

SMA198D

D3116D

02.97

Page 21

NB: Safety components marked with must be replaced with original or approved components only.  
All printed boards and the back cover are a US safety components

# DEFLECTION PROCESSOR

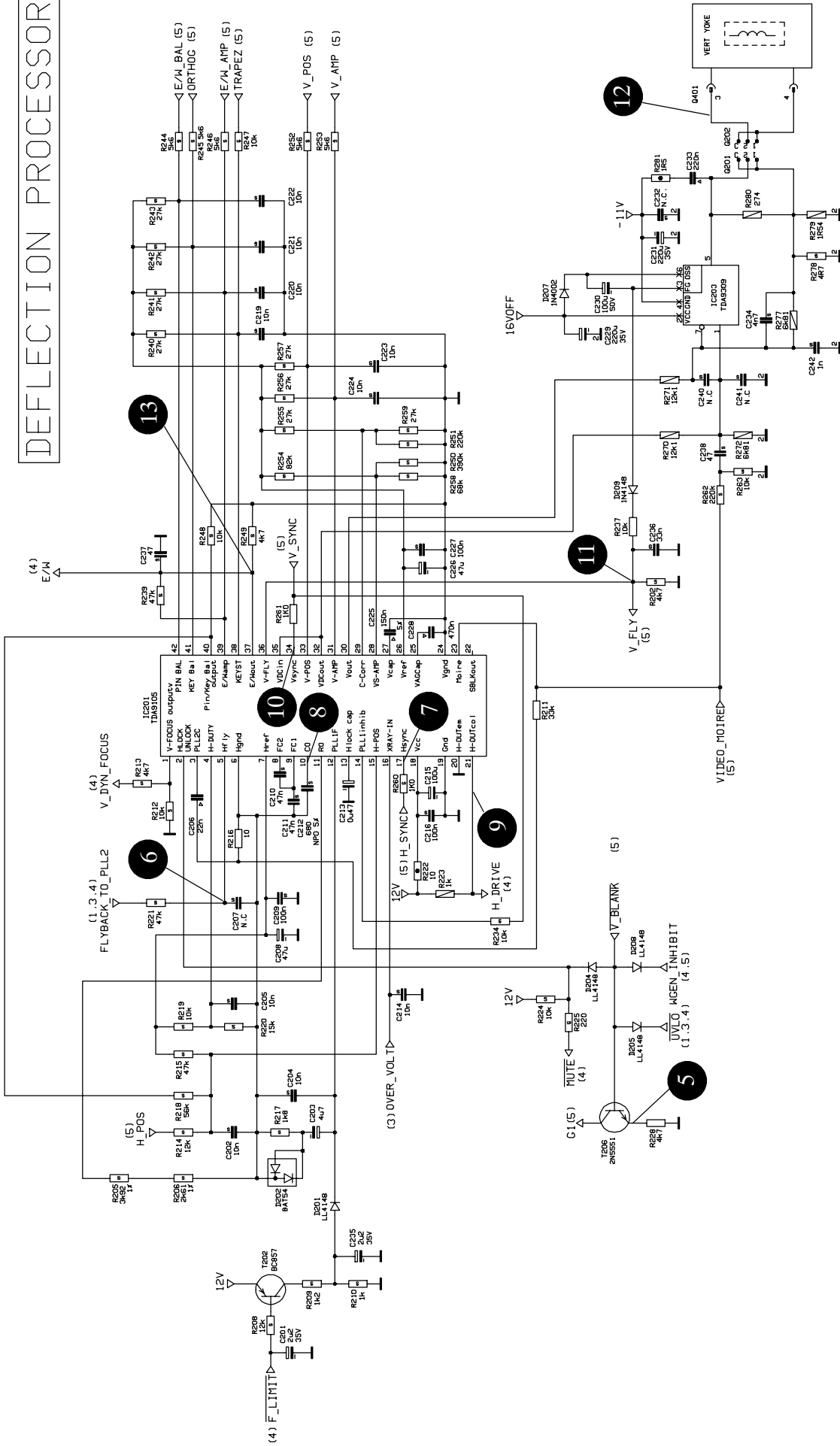

# VERT. OUTPUT

560093D



Symbol	CERAMIC	POLYPROPYLENE	POLYESTHER POLYCARBONATE
	<= 63 V	<= 63 V	<= 63 V
	<= 160 V	<= 160 V	<= 160 V
	<= 250 V	<= 250 V	<= 250 V
	<= 500 V	<= 500 V	<= 400 V
	<= 1.5 kV	<= 1.5 kV	<= 1.5 kV





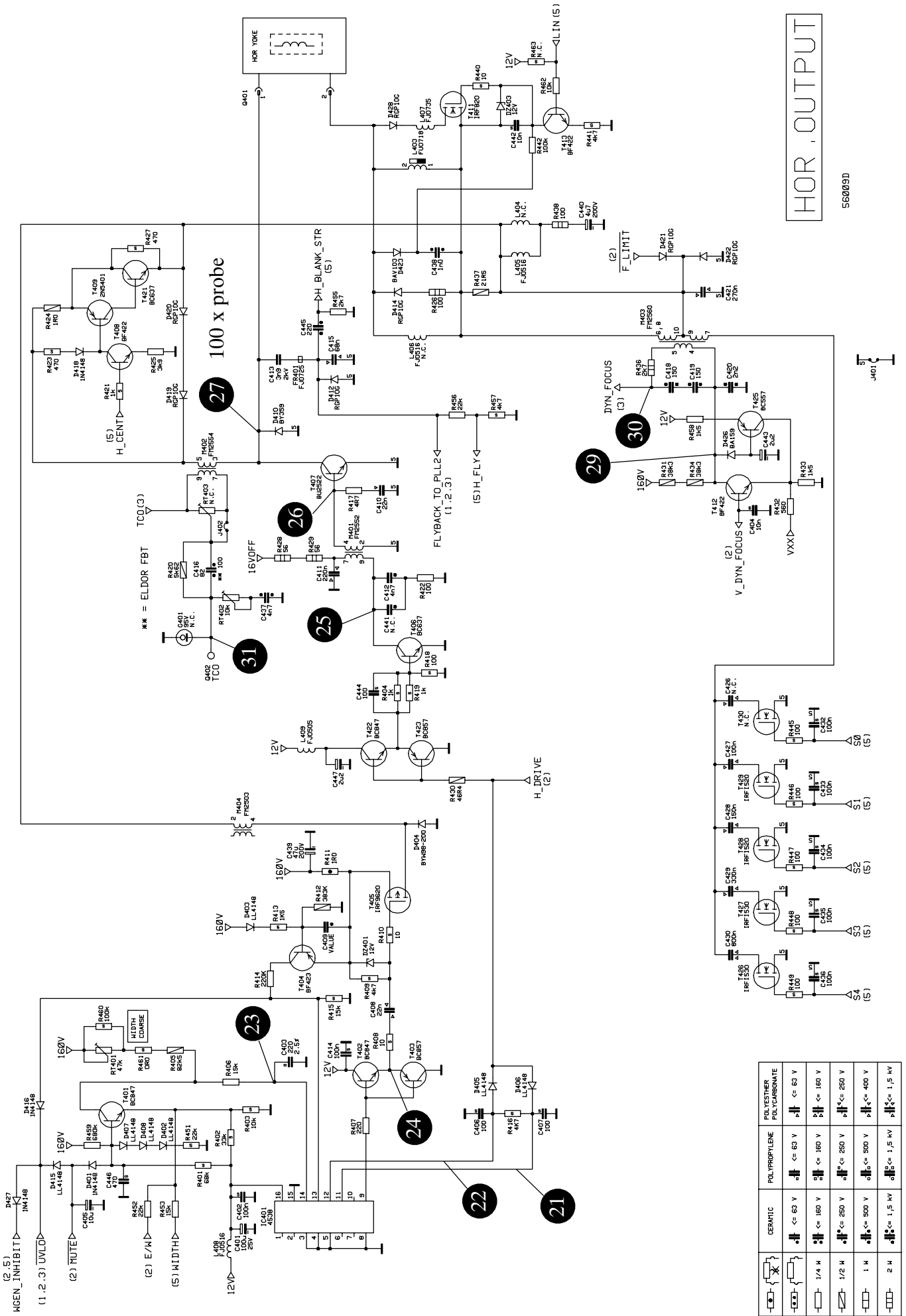

Material	Value	Rating
CERAMIC	< 63 V	< 1.5 kV
POLYPROPYLENE	< 63 V	< 1.5 kV
POLYESTHER	< 63 V	< 1.5 kV
POLYCARBONATE	< 63 V	< 1.5 kV
	1/4 H	< 160 V
	1/2 H	< 250 V
	1 M	< 500 V
	2 H	< 1.5 kV

HOR. OUTPUT

56009D

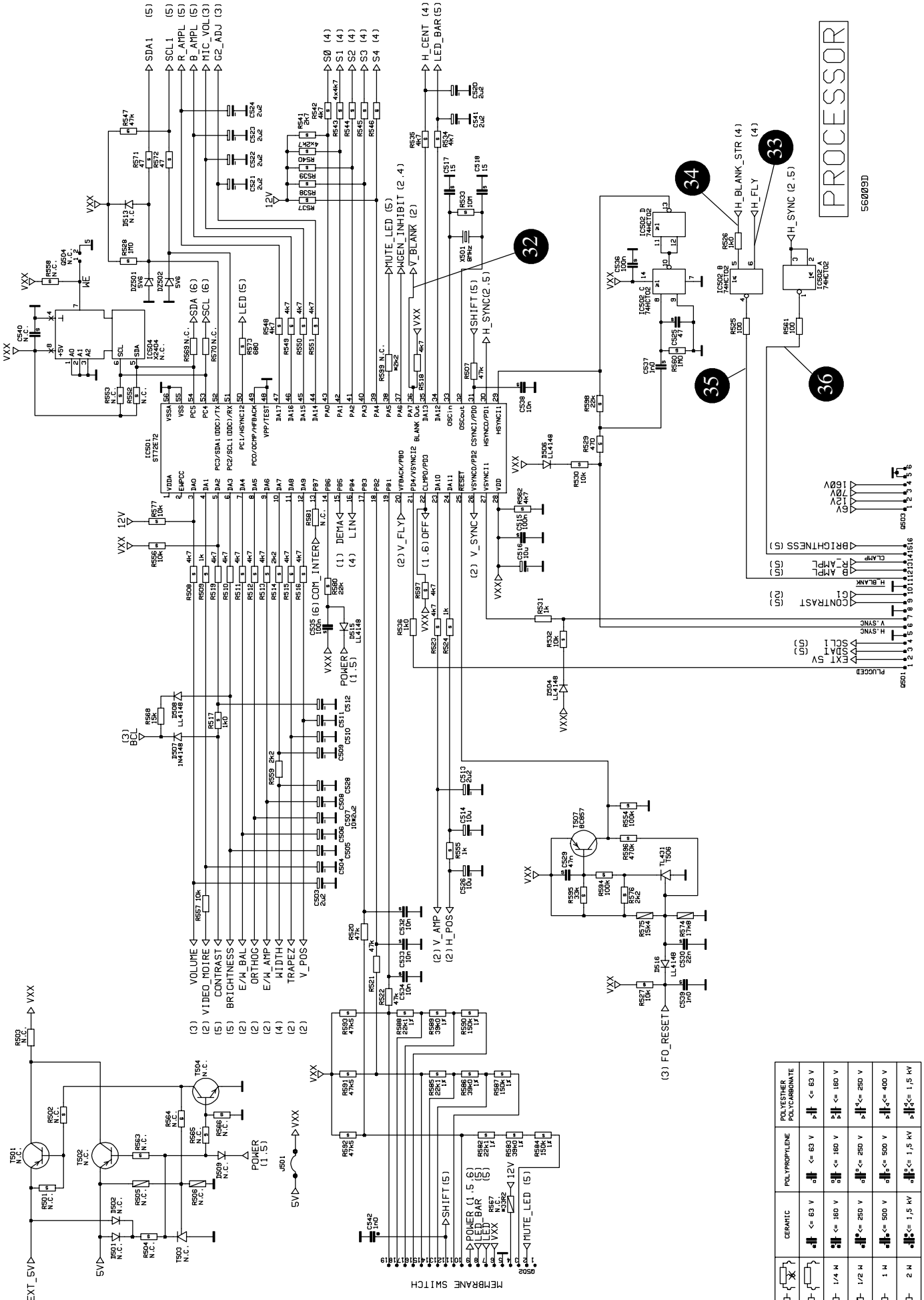

Component	Material	Value	Temperature Coefficient
Resistor	Ceramic	<= 63 V	<= 63 V
Resistor	Polypropylene	<= 180 V	<= 180 V
Resistor	Polyester	<= 250 V	<= 250 V
Resistor	Polyester	<= 500 V	<= 500 V
Resistor	Polyester	<= 1.5 kV	<= 1.5 kV
Capacitor	Ceramic	<= 1.5 kV	<= 1.5 kV
Capacitor	Polypropylene	<= 180 V	<= 180 V
Capacitor	Polyester	<= 250 V	<= 250 V
Capacitor	Polyester	<= 500 V	<= 500 V
Capacitor	Polyester	<= 1.5 kV	<= 1.5 kV

**SMA198D**  
D3116D 02.97 Page 25

PROCESSOR  
56009D

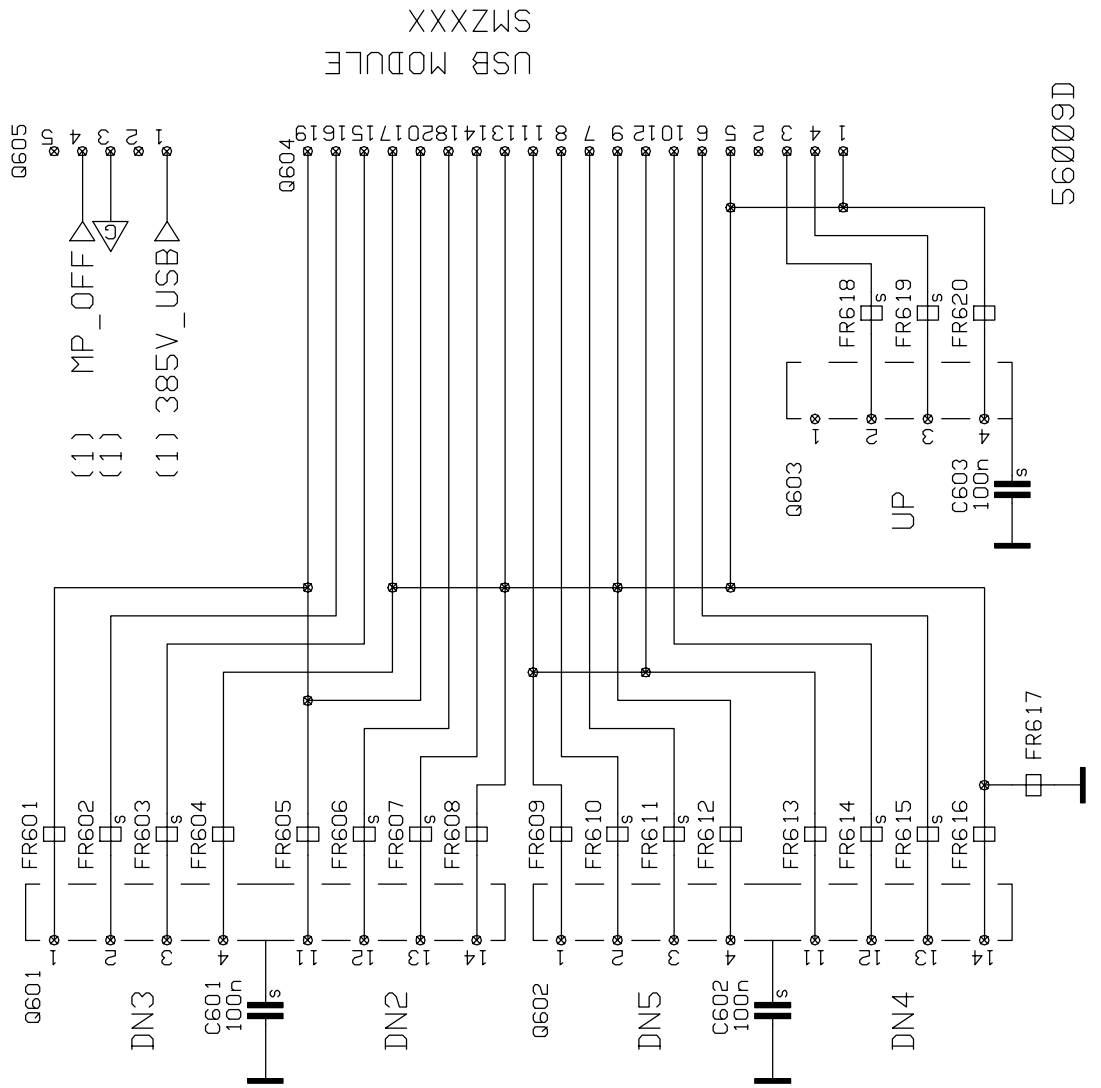
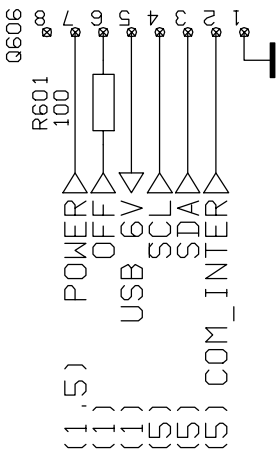

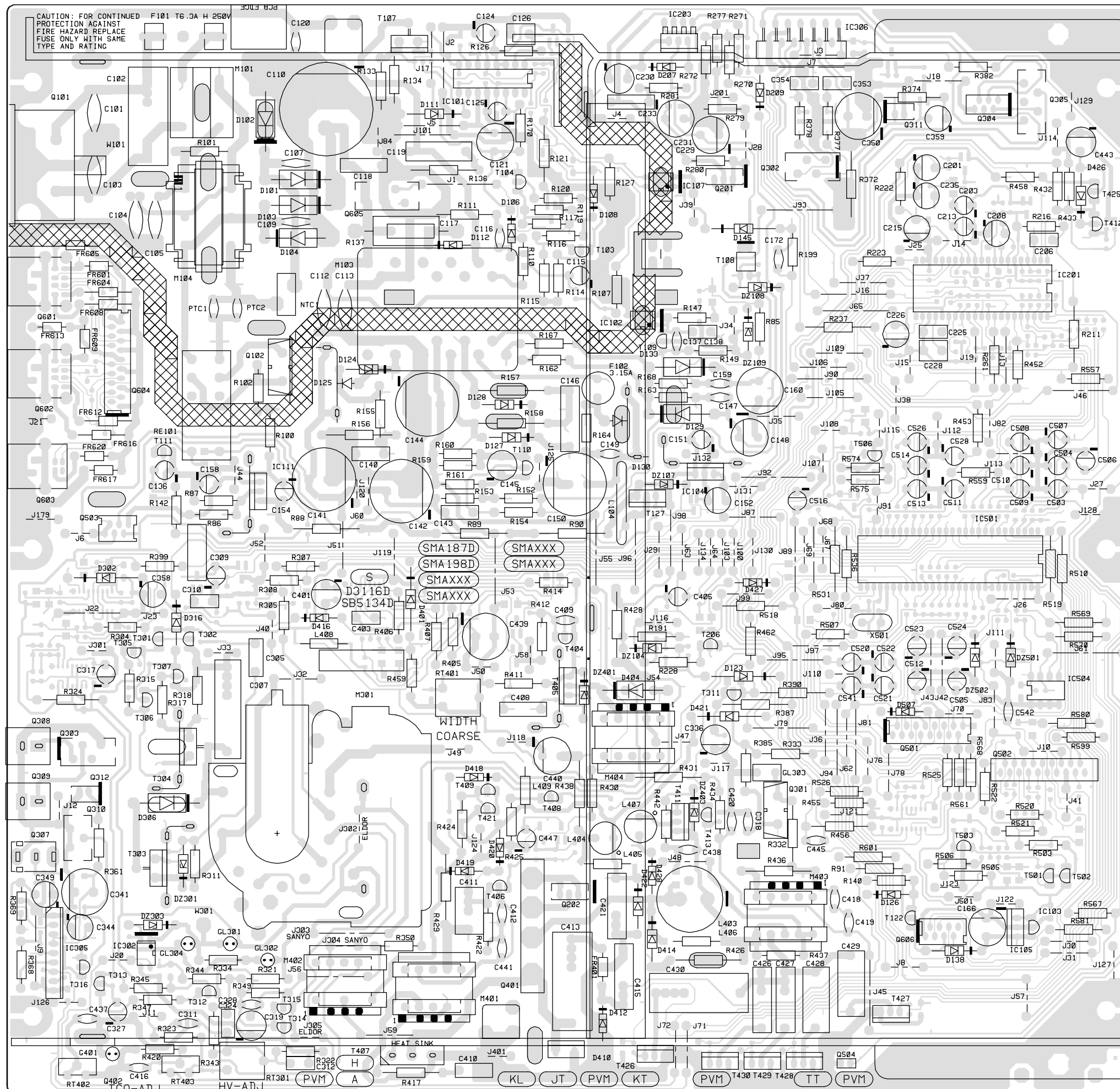

CAUTION: FOR CONTINUED PROTECTION AGAINST FIRE HAZARD REPLACE FUSE ONLY WITH SAME TYPE AND RATING

