

Service Manual

ViewSonic G800

Model No. G800

*20" Digital Controlled Color Monitor
Graphics Series*



(Rev. 1 - February 97)

ViewSonic® 20480 E. Business Parkway, Walnut, California 91789 USA - (800) 888-8583

Preface

Before You Start

General Safety Precautions

1. Use an isolation transformer in the power line and AC supply to troubleshoot.
2. When servicing, observe the original lead dress, especially in the high voltage circuits. If a short circuit is found, replace all parts which have been overheated or damaged.
3. Before turning the display on, measure the resistance between B+ line and chassis ground. Connect the negative side of an ohmmeter to the B+ lines and the positive side to chassis ground. Each line should have more resistance than the following specifications:

B+ Line	Minimum Resistance
+215V	148.25K Ω
+78V	88.55K Ω
+15.0V	1.17K Ω
-12V	33.38K Ω
+6.3V	3.39 Ω
+5.0V	1.32K Ω

4. Potentials, as high as 25kV are present when this display is in operation. Operation of the display without the rear cover involves the danger of a shock hazard from the display power supply. Servicing should not be attempted by anyone who is not thoroughly familiar with the precautions necessary when working on high voltage equipment. Always discharge the anode of the picture tube to the display chassis before handling the tube.
5. After servicing, be sure to check the items listed in the Safety Checkout, below before returning the serviced unit to the customer.

Safety Checkout

The following checks must be made after correcting the original service problem and before the unit is returned to the customer.

1. Check the area of your repair for unsoldered or poorly soldered connections. Check the entire board surface for solder splashes and bridges.
2. Check the inter-board wiring to ensure that no wires are pinched or coated with high-wattage resistors.
3. Check that all control knobs, shields, covers, ground straps and mounting hardware have been replaced. Make absolutely sure you have replaced all the insulators.
4. Look for any unauthorized replacement parts, particularly transistors, that may have been installed during a previous repair. Point them out to the customer and recommend their replacement.
5. Look for parts which, though functioning, show obvious signs of deterioration. Point them out to the customer and recommend their replacement.
6. Check the line cord for cracks and abrasion. Recommend the replacement of any such line cord to the customer.
7. After making any repair, check the B- and HV to see whether they are at the values specified. Make sure your instruments are accurate; if your HV meter always shows a low HV, check the meter to ensure it is not malfunctioning.
8. Carry out the leakage current checks as detailed below overleaf.

Leakage Current Cold Check

1. Unplug the AC cord and connect a jumper between the two prongs on the plug.
2. Turn on the display power switch.
3. Use an ohmmeter to measure the resistance value between the jumpered AC plug and each exposed metallic cabinet part on the display, such as screwheads, terminals control shafts, etc. When an exposed metallic part has a return path to the chassis, the reading should be between 243k and 5.2M. When exposed metal does not have a return path to the chassis, the reading must be:

over pl
at e
our e
sista
er. I
ipe is
at e n
le and
to the
illiana



Section 1.

Product Specification

1.1.	Monitor Control Locations and Functions	1-1
1.2.	Product Overview	1-2
1.3.	CRT Characteristics	1-2
1.4.	Power Specifications	1-2
1.5.	Video Specifications	1-2
1.6.	Sync Input Signal Characteristics	1-2
1.7.	Environmental	1-3
1.8.	Preset Timing Modes	1-3

1.1. Monitor Control Locations & Functions

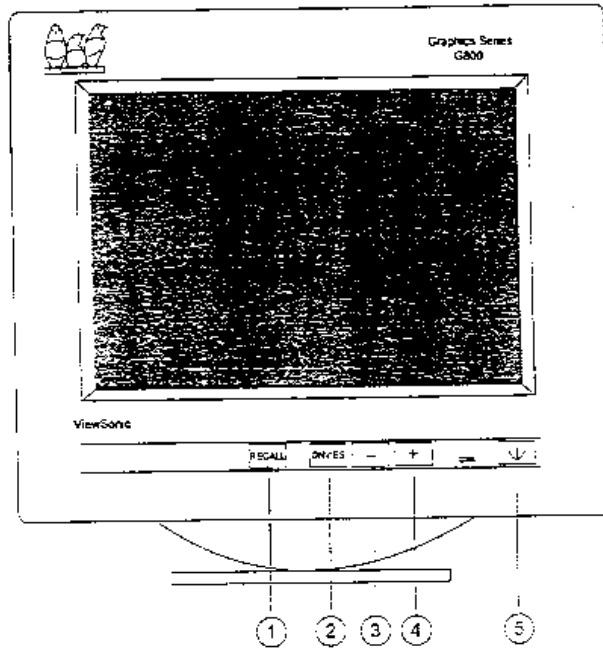

KEY TO BUILT-IN MONITOR CONTROL FUNCTIONS		
(1)	Factory Setting Recall Function	Press to RECALL button for recall the original factory setting and dim OSD pattern is on screen.
(2)	Push Button for OSD On/Off and Selection Confirm	Press to call up OSD functions onto screen and confirm the "+", "-" button selection for OSD icon.
(3)	"-" Button for Adjusting Setting and OSD Function Selection	"-" button for adjusting the setting and decreasing and selection the OS function icon.
(4)	"+" Button for Adjusting Setting and OSD Function Selection	"+" button for adjusting the setting and increasing and selection the OS function icon.
(5)	Power On/Off	Hard power On/Off button. Adjacent LED is lit when on. The LED color green for normal condition and change to orange for DPMS condition.

1.2. Product Overview

The monitor installed in the G800 (G800-1) phone described in this service manual has the following features:

- 20 inches 0.28mm dot pitch conventional C.R.T
- 30~86kHz horizontal scanning
- 50~120kHz vertical refresh rate scanning
- 28 total memory modes in standard configuration
- Universal segmented auto range Power Supply
- VESA/NUTEK/EPA compliant power management

1.3. CRT Characteristics

- Screen Size 20 inches
- Faceplate Type Cylinder
- Phosphor Dot Pitch 0.28mm, stripe pitch
- Electron Gun 29mm, In-Line high resolution gun
- Deflection Angle 90 degree diagonal
- Shadow Mask Invar
- Phosphor Type P22
- Phosphor Persistence Medium Short
- Standard Light Transmission 52% Typical

1.4. Power Specifications

1.4.1. Power Supply

- A/C Receptacle IEC320
- Power Supply Type Universal
- A/C Line Voltage Ranges .. 85VAC-132VAC
180VAC-264VAC
- A/C Line Frequency Ranges 50Hz/60Hz±3Hz
- Inrush Current 30A/132V or
50A/264V (at cold start)
- Leakage Current ≤3.5mA
- Degauss. Automatic and Manual
(20 minutes for a full recovery)

1.4.2. Power Management

Summary of operating states:

APM State	LED Color	Power Consumption	Automatic Recovery Time
On	Green	< 150W	Not applicable
Standby	Orange	< 30W	<3 seconds
Suspend	Orange	< 8W	<10 seconds
Off	Orange	< 8W	<10 seconds
Self test	Green	< 150W	Not applicable

- Signaling compliant with VESA DPMS guidelines
- Nutek 1992 guidelines Suspend < 30 watts,
off < 8 watts

- EPA Energy Star Standby < 30 watts

1.5. Video Specifications

1.5.1. Video Amplifier Performance

- Bandwidth (dot rate) 135MHz
- Typical 10%-90% rise and fall times.....calculation
5.5ns
- Video generator rise / fall times.....2ns maximum
- Scope and probe bandwidth. 350MHz minimum
- Probe capacitance. 2.5pf
- Overshoot / Undershoot..... 10% maximum
- Sync on green. Amplitude : 714mV maximum.
sync on green amplitude : 286mV maximum

1.5.2. Video Input Signal Characteristics

- Video Type Analog
- Amplitude 700mV maximum
- Video Input Impedance 75 Ohms±1%
- Optional DDC 1/2B video Connector Pin Assignments:

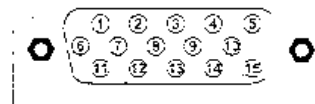

pin	Signal	pin	Signal	pin	Signal
1	Red video	6	Red return	11	Monitor GND
2	Green video	7	Green return	12	SDA
3	Blue video	8	Blue return	13	H. sync
4	Monitor GND	9	No pin	14	V. sync(VCLK)
5	No pin	10	Sync return	15	SCL

1.6. Sync Input Signal Characteristics

1.6.1. Separate Sync

- Sync Type TTL
- Amplitude 2.4V minimum
(Logic High), 0.8V max.(Logic Low)
- Polarity Positive or Negative
- Equalization pulses Not allowed

1.6.2. Composite Sync

- Sync Type TTL
- Amplitude 2.4V minimum(Logic High)
0.8V max.(Logic Low)
- Polarity Positive or Negative

Leakage Current Hot Check

1. Plug the AC cord into the AC outlet. Do not use an isolation transformer for this check.
2. Connect a 1.5k, 10 watt resistor in parallel with a 0.15F capacitor between each exposed metallic part on the set and a good earth ground (see How to Find a Good Earth, below) as shown in the diagram below.

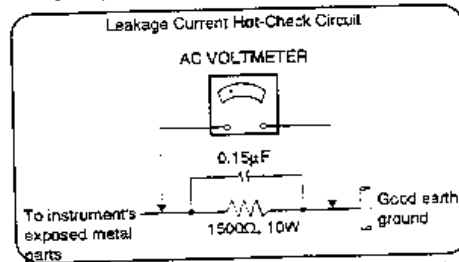

Example of Leakage Current Hot-Check Circuit

3. Use an AC voltmeter with 1000 ohms/volt or more sensitivity to measure the potential across the resistor.
4. Check each exposed metallic part, and measure the voltage at each point.
5. Reverse the polarity of the AC plug in the AC outlet and repeat the above measurements.
6. The potential at any point should not exceed 0.75 volt RMS. A leakage current tester (Simpson Model 229, RCA WT-540A or equivalent) may be used to make the hot checks.

Leakage current must not exceed 0.5 milliamp. If a measurement is outside of the specified limit, there is a possibility of a shock hazard and the monitor should be repaired and rechecked before it is returned to the customer.

How to Find A Good Earth

A cold water pipe is a guaranteed earth ground; the cover retaining screw on most AC outlet boxes is also at ground. If the retaining screw is to be used as your ground, verify that it is at ground by measuring the resistance between it and a cold water pipe with an ohmmeter. Reading should be zero (0) ohms. If a cold water pipe is accessible, connect a 60-100 watt trouble light (not a lamp) between the hot side of an AC power receptacle and retaining screw. Try both slots, if necessary, to locate the side of the line. The lamp should light at normal brilliance if the screw is at ground potential.

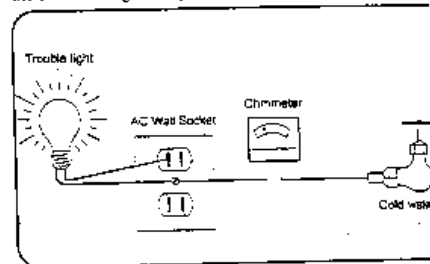

How to Check for Earth Ground

- Serration pulses Allowed at horizontal rate
- Equalization pulses Not allowed
- Total Times 180 Minutes

1.6.3. Sync On Green

- sync Type As per Apple
- Amplitude 0V minimum (Logic High)
-286mV max.(Logic Low)
- Polarity Negative/composite
- Serration pulses Allowed at horizontal rate
- Equalization pulses Not allowed

1.7.3. Drop Test

- Compliant with NSTA Project 1A guidelines
- Drop Height 51cm
- Test Direction 1 Corner, 3 Edges, 6

1.7. Environmental

1.7.1. Temperature/Humidity/Altitude

OPERATING :

- Temperature 10°C to 40°C
- Relative Humidity ... 0 to 90% non-condensation
- Altitude -400 to 3,000 feet

Note: The display will operate within 10°C to 40°C in all modes but may not meet all the visual performance criterion listed in spec section 7.0 at temperature extremes.

NON-OPERATING :

- Temperature -40°C to +65°C
- Relative Humidity ... 0 to 93% non-condensation
- Altitude -40 to 12,000 feet

1.7.2. Vibration Test

UNPACKED UNIT :

	Frequency	Amplitude	Acceleration(G)
1	5-22Hz	0.25mm	-
2	22-500Hz	-	0.25G

Times/Cycle:

- Rise Time 10 Minutes
- Fall Time 10 Minutes
- Number of Sweeps 1 Cycle
- Axis X,Y,Z
- Total Times 60 Minutes

PACKAGED UNIT :

	Frequency	Amplitude	Acceleration(G)
1	5-250Hz	-	1.00G
2	-	-	-

Times/Cycle:

- Rise Time 10 Minutes
- Fall Time 10 Minutes
- Number of Sweeps 1 Cycle
- Axis X,Y,Z

1.8. Preset Timing Modes

This display has 11 preset display modes configured for manufacture, given in the following table:

Model No.	Hf KHz	Vf Hz	Dot x Lin
01	81.250	65.000	1600x10
02	79.976	75.025	1280x10
03	68.680	75.060	1152x8
04	63.981	60.020	1280x10
05	60.241	74.927	1024x8
06	60.023	75.029	1024x8
07	49.725	74.550	832x6
08	46.875	75.000	800x6
09	37.500	75.000	640x4
10	31.469	59.942	640x4
11	31.250	69.400	640x4

Section 2.

Disassembly Instructions

- 2.1. Removing the Base and the Rear Cover 2-1
- 2.2. Removing the Neck Board and Main Board 2-2
- 2.3. Removing the Control Board 2-3

2.1. Removing the Base & the Rear Cover

1. Remove the screw at the base. Refer to the figure 2-1 (A).
2. Remove the base.
3. Remove the six screws at the rear of the display. Refer to the figure 2-2 (A).
4. Remove the rear cover.

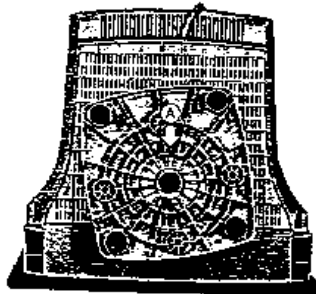

Figure 2-1 Remove the Base

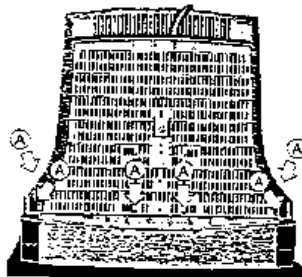

Figure 2-2 Remove the Rear Cover

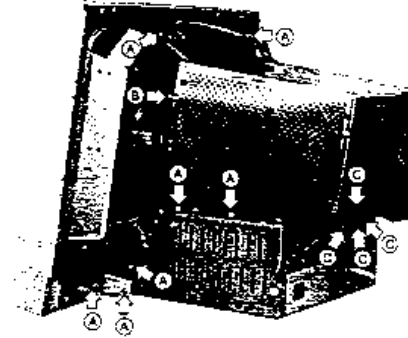

Figure 2-3 Internal Disassembly (Right side)

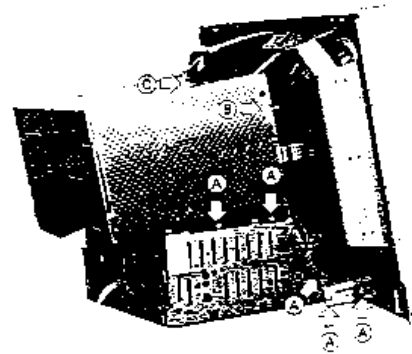

Figure 2-4 Internal Disassembly (Left Side)

2.2. Remove the Top Shield & Rear Shield

1. Remove the seven screws. Refer to the figure 2-3 (A).
2. Disconnect the ground wire from the top shield. Refer to the figure 2-3 (B).
3. Disconnect the five ground wires from the neck shield and top shield. Refer to the figure 2-3 (C).
4. Remove the five screws. Refer to the figure 2-4 (A).
5. Disconnect the ground wire from the top shield. Refer to the figure 2-4 (B).
6. Release the crammer cord from the top shield. Refer to the figure 2-4 (C).

2.3. Remove the Neck Board & the Main Board

The neck board is plugged on to the CRT neck and is encased in a metal shielding.

1. Disconnect the ground wire from the neck shield. Refer to the figure 2-5 (A).
2. Remove the two connected pins from the main board. Refer to the figure 2-5 (B).
3. Release the cord crammer. Refer to the figure 2-5 (C).
4. Cut the cable tie indicated to free the cables. Refer to figure 2-6 (A).
5. Disconnect the two ground wires from the main board. Refer to the figure 2-6 (B).
6. Remove the connected pin. Refer to the figure 2-6 (C).

IMPORTANT NOTE

To avoid risk of electric shock, before removing the anode cap, make sure the anode has been completely discharged as high voltage may remain on the anode for extended time after power off.

7. Remove the anode cap from the CRT. Refer to the figure 2-6 (D).
8. Remove the ground wire from the neck shield. Refer to the figure 2-6 (E).
3. Remove the neck shield.
4. Remove neck board.
5. Remove the main board.

2.4. Remove the Control Board

1. Remove the two screws from the control board. Refer to the figure 2-7 (A).
2. Remove the control board.

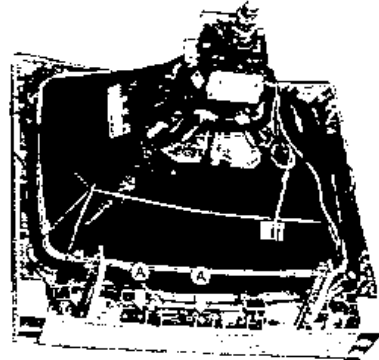

Figure 2-7 Remove the Control Board

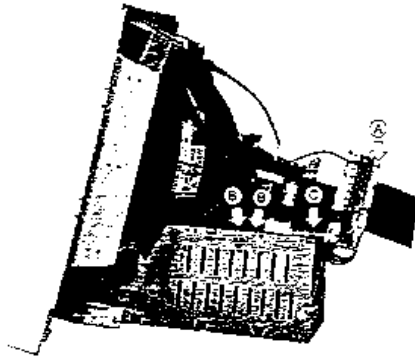

Figure 2-5 Remove the Neck Board & the Main Board

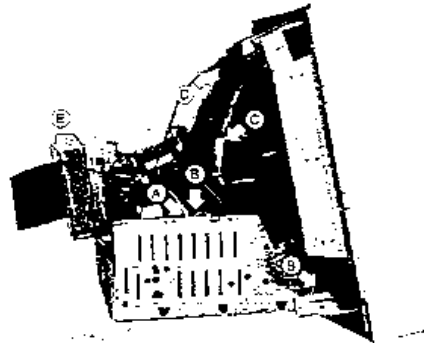

Figure 2-6 Remove the Neck Board & the Main Board

Section 3.

Theory of Operation

3.1.	Switching Power Supply	3-1
3.2.	The Deflection Circuit	3-2
3.3.	Video Amplifier	3-12
3.4.	Microprocessor and Sync Processing.....	3-13

3.1. Switching Power Supply

The switching power supply (SPS) used in this display is a 150W flyback mode type. The power supply provides six outputs (215V, 78V, 15V, -12V, 6.3V and +5V). Please refer to schematic diagram for details of the circuit layout. The input voltage is from 88VAC — 264VAC with an input frequency of 47Hz — 63Hz, as shown in figure 3-1.

The current first passes through the EMI control circuit and is regulated to DC by the bridge diode (BD901) and filter capacitor (C907). During rectification a large current surge is generated and as C907 has a very low impedance while being charged the fuse, on/off switch and bridge diode are all liable to be damaged. For this reason, a thermal resistor (NTCR) is added before the bridge diode in order to limit the large current surge generated during the charging of the capacitor.

During rectification, C910 is charged through R903 and R904. When C910 is charged to 16V, IC901 3842A starts to operate (for details, of the functions of this IC, please refer to the relevant data sheet) and outputs a pulse signal from Pin 6 to set the transistor Q902 in the ON state. At this time, transformer T903, which is connected in parallel, starts to store power. When the current passing through the resistor R914, and the supplementary current from R957 and R964 into Pin 3 of IC901 reaches 1.1V, IC901 is reset, causing the energy stored by the transformer to reach the rated value. In order to prevent the transformer from being saturated and causing damage to the transistor, when transistor Q902 is in the OFF state, the energy stored in the transformer T903 is released into the secondary coil and is regulated through the various output loops and filters and converted to the required DC output. In addition to this, at the appropriate time, the windings pin1 — pin2 supply Pin 7 of IC901 with a fixed power supply for normal operation. Also, when windings pin2 — pin3 are in power saving active state, power is supplied to Pin 7 of IC901 for normal operation.

In any of the above cases, the output pulse is terminated the FET is turned off, causing the voltage on the output: FET to rise rapidly, and the voltage across the winding: primary to reverse in polarity, thus tending to reset it within the core. At this point, the diodes D915, D916, D920, D925 and D926 on the secondary supply will become forward biased and begin to conduct, thus transferring energy from primary to the secondary, and charging secondary capacitors.

There is also secondary winding the primary side of the supply which, through diode D908 and Q901 recharges control IC901 reservoir capacitor C910. This supply keeps the IC901 running. In the event of a secondary circuit, the supply fails to recharge, thus the voltage on C910 drops to a threshold limit below which the IC901 cuts out and returns to its low current load operation.

During normal operation, the supply rails charge an error amplifier realized by IC903 on the secondary before turning on the opto-coupler, PH901. At this point, the photo transistor of this opto-coupler on the primary side begins to conduct, draining current from the primary control supply through diode D907 and D923.

Under normal operation IC903 regulates the current through PH901, and hence determines the output voltage of the error amplifier internal to IC901. Various passive components around IC903 and IC901 set the gain compensation optimum stability and regulation characteristics.

In the event of a fault condition occurring, either Q902 is turned on by the lack of voltage at pin3 of IC901, or diode ZD903 may conduct, due to excessive voltage: primary IC901 supply. In the latter case, the triac Q903 fires, thus dragging down the output of the control IC901 amplifier, which in turn will limit the duty cycle and the output voltage. It will stay in this mode until the AC power is removed.

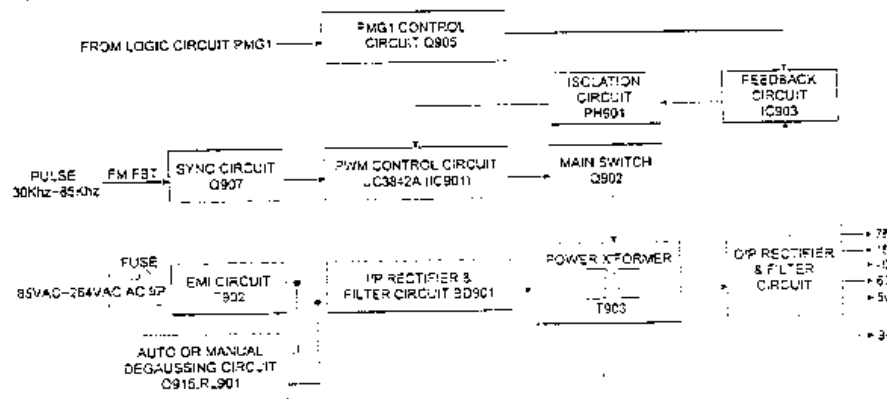

Figure 3-1 Switching Power Supply Block Diagram

When the feedback signal passing through the main 78V output is completed, the transistor's duty cycle is adjusted through the transfer to Pin 2 of IC901 3842A of the primary coil by PH901 4N35 and IC903 TL431, stabilizing the output current. At this time, it is important to note that before the feedback signal is established, the charge level of C917 cannot trigger Q903 SCR or it will cause a faulty power startup. In addition, in order to synchronize the supply power and monitor and reduce noise that will cause interference to the display, in the area D913 the monitor's feedback transformer gets a feedback signal in order to ensure synchronization between the power supply and monitor, with synchronization in the range 30kHz — 85kHz. Because the power operating frequency changes with the monitor causing changes in the value of IP, (the value of LP is fixed while the value of IP increase or decreases according to the frequency), this affects the test value of Pin 3 of IC901 3842A. This causes the total power supplied to vary according to the frequency, so a compensation value is provided by D914 in order to reduce the difference in total power for different frequencies. In addition, because the AC input ranges from 85VAC to 264VAC, this causes the value of the direct current on the DC bus to vary, affecting the rise rate of IP, the oscillator and the duty cycle, and causing the test value obtained at Pin 3 of IC901 to vary. To resolve this, a compensation value is provided by R964 and R957 which reduces the difference resulting from the different input voltages.

3.1.1. Auto-degaussing

When base of Q915 connector is in high state, the transistor Q915 2SC945P is on, causing the relay to jump from Normal Open (N.O.) to Normal Close (N.C.) to perform auto-degaussing operations. The duration of this operation is controlled by a logic pulse and lasts approximately 6 (six) seconds. When transistor Q915 enters the OFF state and the relay returns to N.O., to terminate the auto-degaussing operation is completed.

3.1.2. Suspend Mode Operation

Two feedback ratios can be selected, both sensing from the 78V rail. In the event of Q905 being turned on by micro processor, additional current is drawn from the virtual earth node of IC903, thus causing the power supply to serve the rail to a high voltage, nominally 78V. This is trimmed by resistor R937, R940 and R941. The other supply rail are predetermined ratios of this winding, being +15V, +12V, 6.3V and 215V nominally. In addition, a low voltage primary side winding feeds the control IC901 directly through D907 turning off the control IC901 supply through Q901, which would otherwise dissipate excessively.

When Q905 is turned off, the 78V rail drop to around 17V. In this case, the primary control supply fed through D907 drops to a value that is below the level needed to sustain operation. Instead, Q901 begins to conduct and the higher voltage supply winding taken

via D908 is used to keep the primary side powered up with minimal power losses.

The 5V power supply is driven by one of two sources. In normal operation when the 78V is present, the 5V regulator, IC902 is fed from the 15V rail through diode D921. When switched to standby mode (78V rail drops to 12V) then the 15V rail drops too low to supply IC902. In this case Q906 take over and maintains the supply to IC902 at around 9V.

In addition to the 5V regulated supply, in normal operation there is also a 15V regulated supply take from the 15V rail.

To ensure that micro processor gets a good 5V power supply, there is a power good detection circuit formed by Q801 and Q802. This monitors the supply going into the 5V rail (not the 5V rail directly). It detects whether there is sufficient voltage to enable the 5V regulator to work effectively. It is not a detection of the 5V rail itself, but relies upon the premise that the regulator is not faulty and that there is no faulty load condition on the 5V.

During power up, there is a delay to the signal at the output of the threshold comparator Q801 and Q802 a caused by ZD801 and CS01, in order to allow the micro circuit time to stabilize. The threshold is chosen such that the RESET line drops low at least 25ms before the 5V drop out of regulation.

Finally a synchronization pulse taken from the horizontal output stage maintains the SMPS operating frequency in sync with the horizontal scan. D913 injects a pulse which prematurely triggers the oscillator within IC901 which would otherwise run at a frequency lower than the minimum required sync frequency.

3.2. The Deflection Circuit

Please refer to the block diagram of the deflection circuit and video circuit and Logic circuit as shown in figure 3-2.

3.2.1. IC301 LM1292 Video PLL System for Continuous-Sync

The LM1292 is an integrated horizontal time base solution specifically designed to operate in continuous-sync video monitors. It automatically synchronizes to any H frequency from 30kHz to 85kHz and provides the drive pulse to the high power deflection circuit.

Available sync processing includes a vertical sync separator and a composite video sync stripper. An internal sync selection scheme gives highest priority to separate H and V sync, then composite sync, and finally sync on video, so external switching between sync sources is necessary. The LM1292 provides polarity-normalized H/HV and V sync outputs, along with logic flags which show the respective input polarities.

The design uses an on-chip FVC (Frequency to Voltage Converter) to set the center frequency of the VCO

(Voltage Controlled Oscillator). This technique allows autosync operation over the entire frequency range using just one optimized set of external components.

The system includes a second phase detector which compensates for storage time variation in the horizontal output transistor, the picture's horizontal position is thus independent of temperature and component variance.

The LM1292 provides DC control pins for H drive duty cycle and flyback phase.

3.2.2. IC301 LM1292 Pin Descriptions

Pin 1 FVC CAP 2:

Secondary FVC filter pin. Cfvc2 is connected from this pin to ground. The width of the VIDEO MUTE (pin 4) pulse is controlled by the time constant difference between the filters at pins 1 and 25.

Pin 2 Clamp Control:

This low impedance current mode input pin is internally biased to 2V. The direction of current sets the pulse position, while the current magnitude sets the pulse width. A voltage below 2V positions the pulse on the back porch of the horizontal sync pulse and decreasing voltage narrows the pulse. A voltage above 2V sets the pulse on the horizontal sync-tip and increasing voltage narrows the pulse. At the boundary of the switchover between the two modes, there is a narrow region of uncertainty resulting in oscillation, which should be on problem in most applications. When there is no H-sync in sync-tip mode, the clamp pulse is generated by the VCO at the frequency preset by pin 6. This feature is intended for use in on screen display system.

Pin 3 Clamp pulse:

Active-low clamp pulse output.

Pin 4 Video Mute:

This open-collector output produces an active-low pulse when triggered by a step change of H-sync frequency.

Pin 5 F-Max:

A resistor from this pin to ground sets the upper frequency limit of the VCO.

Pin 6 F-Min:

A resistor from this pin to ground sets the lower frequency limit of the VCO.

Pin 7 VCC:

12V nominal power supply pin. This pin should be decoupled to pin 21 (GND) via a short path with a cap (C302) of at least 1000µf.

Pin 8 Vertical Sync In:

This pin accepts AC-coupled vertical sync of either polarity.

Pin 9 Composite Video In:

The composite video sync stripper is active only when no signal is present at pin 12 (H/HV In). The signal to pin 9 must have negative going sync tips which are at least 0.14V below black level.

Pin 10 H/HV Sync Out:

The sync processor outputs active-low H/HV sync derived from the active sync input (pin 9 or pin 12). Pin 10 stays low in the absence of sync input.

Pin 11 H/HV Cap:

A capacitor is connected from this pin to ground for detecting the polarity and existence of H/HV sync at pin 12.

Pin 12 H/HV Sync In:

This pin accepts AC-coupled H or composite sync of either polarity.

Pin 13 H Drive Duty Control:

A DC voltage applied to this pin sets the duty cycle of the horizontal drive output (pin 19). With a range of approximately 30%-70%. 2V sets the duty cycle to 50%.

Pin 14 H Drive EN:

A low logic level input enables H-Drive out (pin 19).

Pin 15 X-ray Shut Down:

This pin is for monitoring CRT anode voltage. If the input voltage exceeds an internal threshold, H-Drive out (pin 19) is latched high and video mute (pin 4) is latched low. Vcc has to be reduced to below approximately 2V to clear the latched condition. IE power must be turned off.

Pin 16 Vertical Sync Out:

The sync processor outputs active-low vertical sync derived from the active sync input (pin 8, pin 9 or pin 12). Pin 16 stays low in the absence of sync input.

Pin 17 Vertical Cap:

A capacitor is connected from this pin to ground for detecting the polarity and existence of vertical sync at pin 8.

Pin 18 Flyback In:

Input pin for phase detector 2. For best operation, the flyback peak should be at least 5V but not greater than Vcc. Any pulse width greater than 1.5µs is acceptable.

Pin 19 Horizontal Drive Out:

This is an open-collector output which provides the drive pulse for the high power deflection circuit. The pulse duty cycle is controlled by pin 13.

Pin 20 Horizontal Drive Ground:

Ground return for horizontal drive out. For best jitter performance, this pin should be kept separate from the system ground (pin 21). The respective ground traces should be met at a single point, located as close as possible to the power supply output.

Pin 21 Ground:

System ground. For best jitter performance, all LM1292 filter components and bypass capacitors should be connected to this pin via short paths.

Pin 22 Voltage Refer Cap:

This is the decoupling pin for the internal 8.2V reference. It should be decoupled to pin 26 (RETURN) via a short path with a cap (C301) of at least 470µf.

Pin 23 Phase Detector 2 CAP:

The low-pass filter cap for the output of phase detector 2 is connected from this pin to pin 26 (RETURN) via a short path.

Pin 24 Horizontal Drive Phase:

A DC control voltage applied to this pin sets the phase of the flyback pulse with respect to the leading edge of horizontal sync.

Pin 25 FVC CAP 1:

Primary FVC filter pin. C1vc 1 is connected from this pin to pin 21 (GND) or pin 26 (RETURN) via a short path. The voltage at this pin is buffered to pin 27 (FVC out).

Pin 26 RETURN:

Ground return for the decoupling capacitor at pin 22 (Vref CAP), the filter capacitor at pin 23 (Phase Det 2 CAP) as well as the loop filter at pin 28 (PD1 OUT/VCO IN). This pin must be isolated from GND and H-drive GND.

Pin 27 FVC Out:

Buffered output of the frequency-to-voltage converter, which sets the VCO center frequency through an external resistor to pin 28. Care should be taken when further loading this pin, since during the vertical interval it presents a high output impedance. Excessive loading can cause top-of-screen phase recovery problems.

Pin 28 PD 1 Out/VCO In:

Phase detector 1 has a gated charge pump output which requires an external low-pass filter. For best jitter performance, the filter should be ground to pin 26 (RETURN) via a short path. If a voltage source is applied to this pin, the phase detector is disabled and the VCO can be controlled directly.

3.2.3. IC302 LM1295 DC Controlled Geometry Correction System

The LM1295 is specifically designed for use in a continuous sync monitor. The injection-locked vertical oscillator operates from 50 Hz to 170 Hz, covering all known video monitors. A differential output current is provided in order to prevent ground interaction.

The IC302 provides two outputs composed of the summation of DC controlled 1st and 2nd order output terms. The first output corrects for EW pincushion and trapezoid. The second corrects for parallelogram and bow.

A DC controlled output is provided for vertical dynamic focus correction.

3.2.4. IC302 LM1295 Pin Descriptions

Pin 1 Ground:

This pin should be connected to the power ground at pin 17.

Pin 2 Vertical Height:

A voltage between 0V and 4V on this pin controls the amplitude of the +V and -V drive currents, with increasing voltage giving increasing current. The control range

is approximately 1.8 to 1. The response time is being limited by the automatic level control loop.

Pin 3 4V CAP:

A C202 capacitor aluminum electrolytic or tant should be connected between pin 3 and GND to bypass the internal 4V reference.

Pin 4 Vertical Sync In:

The vertical sync input takes a negative-going TTL pulse which injection locks the vertical oscillator vertical sync frequency if it is above the LM1295 minimum frequency. The minimum pulse width is approximately 200µs. For free-running detection (no v sync in), this input should be at logic high.

Pin 5 8V CAP:

A C203 capacitor, aluminum electrolytic or tant should be connected between pin 5 and GND (pin 1) to bypass the internal 8V reference.

Pin 6 Vertical Dynamic Height:

A voltage between 3V and 4V on this pin controls amplitude of the +V and -V drive currents with increasing voltage giving increasing current. The control is approximately 1.3 to 1.

Pin 7 Vcc:

Vcc should be bypassed to GND (pin 17) with a aluminum electrolytic or tantalum capacitor. This voltage is 12V.

Pin 8 Voltage Reference CAP:

A C217 capacitor aluminum electrolytic or tant should be connected between pin 8 and GND (pin 1).

Pin 9 Horizontal Dynamic Width:

This output consists of the sum of the vertical ramp, the parabola derived from the ramp. The amplitude polarity of the ramp signal is DC controlled by horizontal trapezoid control (pin 11) and of the parabola by pin control (pin 10). The weighting of the ramp, the parabola, i.e. with the horizontal trapezoid and pincushion controls at 4V, the output is 3 parts parabola and 1 part ramp. Horizontal dynamic width is correct for trapezoid and east-west pincushion correction.

Pin 10 E-W Pincushion Control:

A voltage of 0V to 4V adjusts the polarity and amount of parabola in the horizontal dynamic width output. At approximately 2V, the amount is 0. From 2V to 4V, the amplitude increases and the parabola is positive-going. From 2V to 0V, the amount increases and the parabola is negative-going.

Pin 11 Horizontal Trapezoid Control:

A voltage of 0V to 4V adjusts the polarity and amount of vertical ramp in the horizontal dynamic width output. At approximately 2V, the amount is 0. From 2V to 4V, the amplitude increases and the ramp is positive-going. From 2V to 0V, the amplitude increases and the ramp is negative-going.

Pin 12 Horizontal parallelogram control:

A voltage of 0V to 4V adjusts the polarity and

amount of vertical ramp in the horizontal dynamic center (pin 14) output. At approximately 2V, the amount is zero. From 2V to 4V, the amplitude increases and the ramp is positive-going. From 2V to 0V, the amplitude increases and the ramp is negative-going.

Pin 13 Horizontal Bow Control:

A voltage of 0V to 4V adjusts the polarity and the amount of parabola in the horizontal dynamic center (pin 14) output. At approximately 2V, the amount is zero. From 2V to 4V, the amplitude increases and the parabola is positive-going. From 2V to 0V, the amplitude increases and the parabola is negative-going.

Pin 14 Horizontal Dynamic Center:

This output consists of the sum of the vertical ramp and the parabola derived from the ramp. The amplitude and polarity of the ramp signal is DC controlled by horizontal parallelogram control (pin 12) and of the parabola by horizontal bow control (pin 13). The difference between this output and the horizontal dynamic width output is in the weighting of the ramp, which is equal to the parabola; i.e. with the horizontal parallelogram and horizontal bow controls at 4V, the output is 1 part parabola and 1 part ramp. Horizontal dynamic center is used to correct for parallelogram and bow distortion.

Pin 15 Vertical Dynamic Focus Control:

A voltage of 0V to 4V adjusts the polarity and the amount of parabola in the vertical dynamic focus (pin 16) output. At approximately 2V, the amount is zero. From 2V to 4V, the amplitude increases and the parabola is positive-going. From 2V to 0V, the amplitude increases and the parabola is negative-going.

Pin 16 Vertical Dynamic Focus:

This output consists of the parabola derived from the vertical ramp. The amplitude and polarity are controlled by vertical dynamic focus control.

Pin 17 Ground:

This is the power supply ground for the 12V supply and the point to which the bypass capacitors are returned.

Pin 18 Automatic Level Control CAP:

This capacitor (C204) is part of the level control circuit that maintains constant vertical height in spite of vertical sync frequency changes. If the VCO capacitor value is changed, the capacitor value should change in the same ratio. A R204 resistor should be connected from this pin to ground.

Pin 19 Double Frequency Capacitor:

This capacitor (C218) prevents the vertical oscillator from locking at twice the vertical sync frequency. If the VCO capacitor value is changed, this capacitor value should change in the same ratio.

Pin 20 Oscillator Capacitor:

This is the vertical oscillator capacitor (C232). The value can be changed to change the minimum frequency.

Pin 21 Vertical Resistor:

One end of the vertical resistor connects to this pin. This resistor determines the gain of the vertical ramp current

generator. The gain is inversely proportional to the resistance.

Pin 22 Vertical Resistor:

The other end of the vertical resistor connects to this pin.

Pin 23 Vertical Drive:

This is the negative-going vertical ramp output current of the differential pair. The ramp current waveform is superimposed on a direct current of approximately 315 μ A. The waveform amplitude is determined by the vertical height (pin 2) control voltage and the vertical dynamic (pin 6) control voltage. The current can be converted into voltage by a R236 resistor to ground or by a differential amplifier using the differential currents as inputs. The voltage compliance of the output is typically 6V.

Pin 24 + Vertical Drive:

This is the same as vertical drive except it is the positive-going output current of the differential pair.

3.2.5. Vertical Deflection Circuit

1. IC201 TDA8172 consists of a flyback generator, voltage stabilizer, drive circuit and vertical output amplifier.

2. The vertical oscillator circuit

(a) The frequency and phase of the vertical oscillator circuit is generated by the vertical synchronization signal.

(b) The synchronization signal is input from Pin 4 of IC302 LM1295, and after being processed by the synchronization circuit, is sent to the vertical synchronizer oscillator circuit to trigger the vertical oscillator and synchronize the oscillator frequency with the external synchronization signal. The frequency of its internal free oscillation is set by the time constant of C232. It does not need an external F/V control because this IC302 can keep vertical synchronization. Pin 18 provides vertical A.L.C function. So the pin 18 of IC302 is used to maintain the difference between the free oscillation frequency and external synchronization signal frequency at a similar level and make the sawtooth wave amplitude from pin 24 of IC302 the same.

3. Vertical Size Control

The pulse voltage output by the oscillator is sent to the sawtooth wave generator. The size and amplitude of the voltage of the sawtooth wave generation can be changed by DC value which output from Pin 35 of IC301 (PWM) and the vertical size can thus be controlled. This sawtooth wave voltage passes through a buffer and is output from Pin 24 of IC302 to pin 1 of IC201 TDA8172 of the vertical drive circuit.

The vertical ramp and DC offset are also controlled by PWM output. The vertical ramp gen-

erated across C232 is buffered internally to IC302 by DC controlled variable gain stage. The voltage level is derived from pin 35 of IC801 (PWM) through the R210, R206 and C206 of generation, then into pin 2 of IC302.

4. Vertical Drive Circuit

(a) It is not sufficient to rely solely on the oscillator circuit output to ensure the stability of the vertical output, so a first or second level amplifier circuit must be inserted between the oscillator circuit and the output. This circuit is called the drive amplifier and in addition to amplifying the sawtooth wave also corrects the vertical linearity.

After adding the drive circuit, because the level of amplification can be considerable, enough negative feedback can be added to correct vertical linearity and increase the stability of the circuit.

(b) If the current of the sawtooth wave flowing through the deflection yoke is distorted, then the top and bottom portions of the display will be expanded or compressed, resulting in poor linearity. In order to solve this problem, correction of the linearity of the sawtooth wave can be carried out before the drive level.

5. IC201 TDA8172 Vertical Drive Circuit

The IC201 uses a double power source, so it can be viewed as an OCL drive amplification circuit.

In order that the DC coupled output stage accurate DC reference, a DC reference voltage is taken from pin 5 of IC302. This used as the reference voltage (via divider resistors, R214) for the DC coupled power amplifier (IC201). This is a simple voltage to current inverting amplifier, using R223 to derive a voltage proportional to the current in the deflection winding of the yoke. This voltage is fed back to the virtual signal earth inverting input of the power amplifier (pin 1) by R219. This back to back diode feedback network modifies the linearity of the transfer characteristic in order to give precept "S" correction linearity, in addition to the variable correction in the ramp generator.

The vertical output amplifier has a voltage boost circuit to triple the positive supply voltage during retrace in order to speed up flyback. It does this by charging capacitor C210 through diode D202 during the normal forward scan. Pin 6 of the IC201 is the voltage supply to the power output stage. When flyback occurs, pin 3 is switched to the positive supply rail on pin 2, thus adding the voltage across C210 to that of the supply rail, effective doubling the supply momentarily.

6. Vertical Centering Adjustment

Since IC201 functions as an OCL circuit, its output from Pin 7 of IC201, so the DC current can be changed to shift the on-screen display up or down to prevent voltage fluctuation. The DC operating point of the amp can be varied by the pin 38 of IC801 (vertical position) output and via R212, C207 and to pin 7 of IC201 which adds or subtracts offset into the output, thus varying the offset of the scan and hence the vertical centering.

3.2.6. Geometry Correction Circuit

1. If the width of the border in the center of screen is insufficient, the waveform shown in Figure 3-3 below, can be used to add horizontal deflection B+ in order to change deflection of the horizontal deflection circuit. This waveform is the parabola obtained regulation of the vertical period, and is used to perform amplitude modulation on the horizontal deflection current, as shown in Figure 3-4.

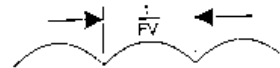

Figure 3-3 Voltage Correction Wave

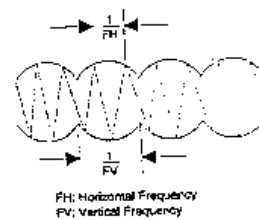

Figure 3-4 Current Correction Wave

2. The sawtooth wave is output from Pin IC302 and through C350 and R364 and to Pin 2 of IC601 (DC to DC circuit). It is output from Pin 6 of IC601 and after being in T603's second coil output, is added to horizontal B+ to provide pin-cushion and trim distortion correction. So, is created to perform amplitude modulation on the horizontal deflection output pulse, as shown in Figure 3-5.



Figure 3-5 Collector of Q303 Output Pulse Correction Wave

- The sawtooth wave is output from pin 14 of IC302 and through R353 and C314 and input to pin 24 of IC301. It is added to horizontal phase to provide parallelogram and bow distortion correction.

3.2.7. Structure of Horizontal Deflection Circuit

The function of the horizontal deflection circuit is to cause left/right scanning of the electron beam using the sawtooth wave current flowing through the horizontal deflection yoke, and is made up of the horizontal oscillator circuit, horizontal drive circuit, horizontal output circuit, synchronous AFC circuit and high voltage generator circuit.

1. Horizontal Drive Amplifier

In order to rapidly saturate the output transistor (ON) or cut it off (OFF), a sufficient basic current must be provided. Because of this, an amplifier circuit is added between the oscillator circuit and the output circuit to amplify the pulse voltage. At the same time, after the waveform has been regulated, by adding this circuit to the output circuit, this amplification circuit functions as a drive amplifier.

IC301 LM1292 consists of a vertical sync selection polarity circuit, composite video sync stripper circuit, AFC circuit, H/V sync and composite sync circuit, voltage control oscillator circuit, phase regulator circuit, X-Ray circuit, video mute circuit, voltage regulator circuit and horizontal drive duty cycle circuit. This IC includes the vertical and horizontal circuits combined in one package.

When the synchronization signal input to logic circuit and pin 12 of IC301. The pin 19 of IC301 output horizontal frequency is achieved by the pin 1 of IC801 and flyback pulse from between C380 and C381 fed to pin 18 of IC301. So, the pin 19 of IC301 output horizontal frequency through Q511, Q512, Q302, Q104, T101 and T301 provide a horizontal output transistor base current of Q303 and horizontal anode voltage generator output transistor base current of Q105.

The horizontal output transistor base drive is taken from a conventional base drive transformer stage. This circuit as in a similar manner to a flyback power supply. The square wave horizontal oscillator output signal is coupled into the base of emitter drive stage transistor Q302, Q304, T301, T101 across the +15V supplies. This causes the primary current to increase linearly until such time as Q302 and Q104 turns off, hence storing a predetermined amount of flux energy in the transformer. As Q302 or Q304 turns off, and the primary current falls to zero, the secondary voltage is driven above the threshold of the base-emitter

junction voltage of the horizontal output transistor Q303 or Q105. Current flows through R320, R321, L301, L302 and D303 into the base of Q303 or through R116, R117, L101 and D130 into the base of Q105 hence turning this device on. The high base current of around 1.1A. Lamps is so high that Q303 or Q105 is driven heavily into saturation. This is important in order that the collector voltage should be as low as low as possible whilst conducting the high peak currents that flow through the horizontal deflection winding. In turn, this is vital to limit dissipation

At the required time as determined by the horizontal oscillator, the base drive transistor is turned back on. The voltage at Q302 or Q104 collector fall rapidly back towards the ground rail. However, the secondary current still remains flowing in a positive direction for a short time, due to the finite leakage inductance of T301 or T101. Also, due to the heavy saturation of Q303 or Q105, the base voltage remains at around 1V. The current in the secondary winding rapidly reverses and goes sharply negative as the charge stored within the base region of Q303 or Q105 is removed. D303 or D130 helps to speed up this charge removal. Note that during this time, the collector output of the Q303 or Q105 is still turned on, even though the base current is flowing out of the base.

This period of time is known as the storage time of the device and may take between 2-3 μ s, depending upon peak collector current and temperature and various other design factors. Finally, when all charge in the base region of Q303 or Q105 is dissipated the base current suddenly stops, and the secondary current drops almost instantly to zero. At that point, the device now become non conducting and the collector current flow also terminates. The secondary voltage on T301 or T101 drops to it's unloaded voltage and the current flow in the primary settles to it initial value once more.

2. Horizontal Equivalent Output Circuit

The horizontal output circuit uses the switch operation of a transistor and a damping diode, and provides a sawtooth wave current to the deflection yoke. The horizontal deflection yoke is made up of the L value on the coil and resistance r inside the coil connected in series. Its resistance is extremely small, and the time constant (L/r) is extremely large. Because of this the voltage at the two terminals of the coil cause rapid variation in the current flowing in the coil still will slowly vary, creating a sawtooth current. The basic circuit and equivalent circuit are shown in Figures 3-5 and 3-7.

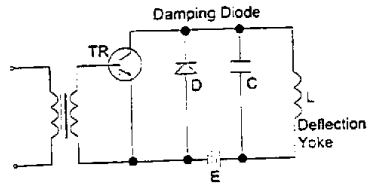

Figure 3-6 The Basic Deflection Circuit

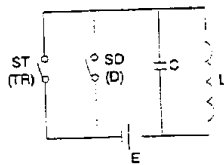

Figure 3-7 Equivalent Circuit

3. Horizontal Output Equivalent Circuit Operation

Refer to Figure 3-8 for the current wave and voltage of the horizontal output circuit during operation.

(a) t_1 — t_2 Period

The base of the output transistor is added forward bias voltage. As the current through the base is very large, it will cause the transistor to be saturated, corresponding to the ON state of S1 in the equivalent circuit. At this time the deflection yoke contains a current and because the time constant is large, a large current will slowly show a linear increase as shown in Figures 3-8 (b) and 3-9 (a).

(b) t_2 - t_3 Period

At t_2 , a negative load is applied to the base and the output transistor changes to OFF (S1 in open state). There is no current passing through the transistor at this time and the C components of the deflection yoke begin to discharge.

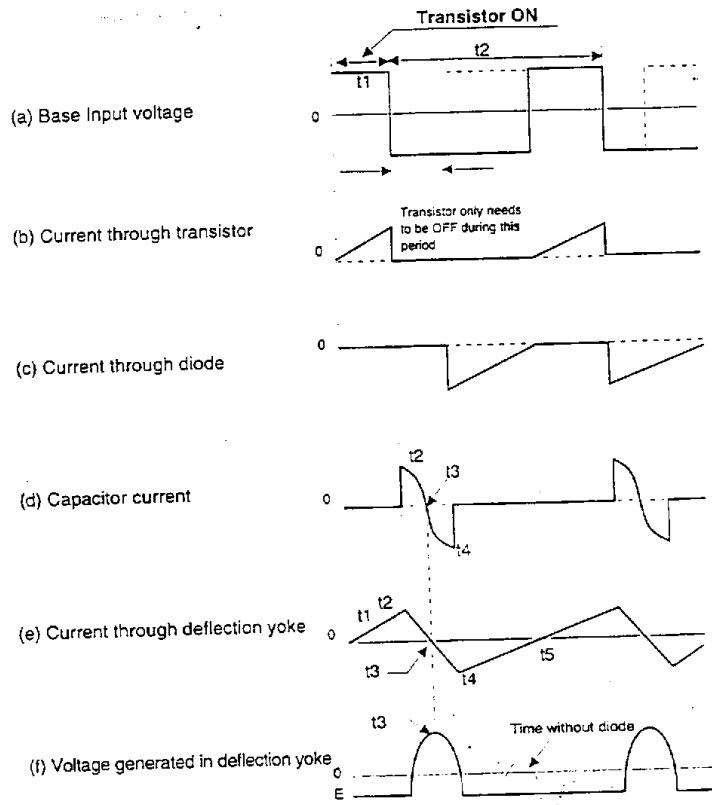

Figure 3-8 Horizontal Output Voltage/Current Waves

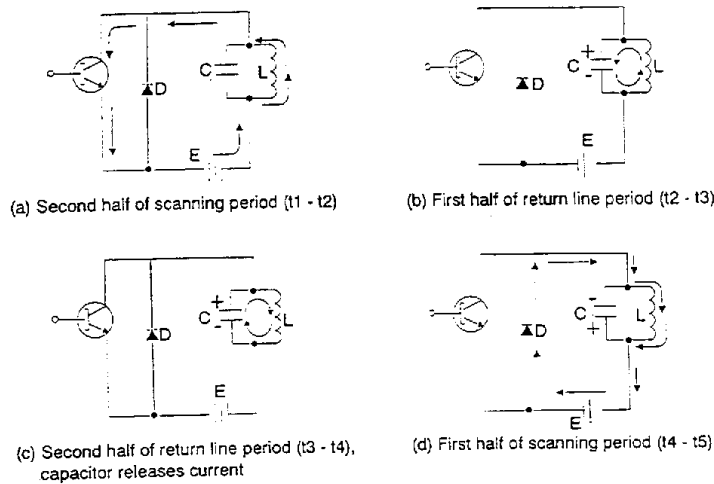

Figure 3-9 Polarity of Transformer Voltage

independent oscillation circuits. If the current is suddenly cut off, then the polarity of the inverse voltage generated at L will be as shown in Figure 3-9 (b). This voltage is viewed as the source voltage and will cause current to flow, at which time the current flowing to C is as shown in Figure 3-8 (d). At time t3 this current is 0 but the voltage at the two capacitor terminals is at maximum. This waveform is known as flyback pulse, and is shown in Figure 3-8 (f).

(c) (t3 — t4) Period

The energy accumulated in C is released to the deflection yoke, the direction of the current flow being shown in Figure 3-9 (c). The current increases as the voltage on C decreases, and at time t4, the voltage of C is 0, at which time the current is at maximum, which means the current flowing into the deflection yoke is also maximum. C is then charged and if a damping resistor is not connected, the energy between L and C will be reversed, which is the oscillation frequency set by the oscillator at L and C.

(d) t4 — t5 Period

At t4, the voltage of C is 0. After this it is recharged in the opposite direction and this voltage exceeds the voltage of the power source at time t4. At this time the damping diode is ON and the L and C circuits are shorted out and stop oscillating. Because of this the time constant of r and L in the damping diode is large so the current flowing in the deflection yoke does not suddenly become 0. The current shows a linear decrease, and when it becomes 0 at time t5 the transistor is ON and the operation described above is repeated.

As described above, the current flowing in the deflection yoke during scanning is the sum of the current which has passed through the transistor and the damping diode current. Please refer to Figure 3-8 (e).

4. Horizontal output operation:

The actual output stage differs from the simple model described in a number of ways. Refer to the basic schematic of the major components in Figure 3-10.

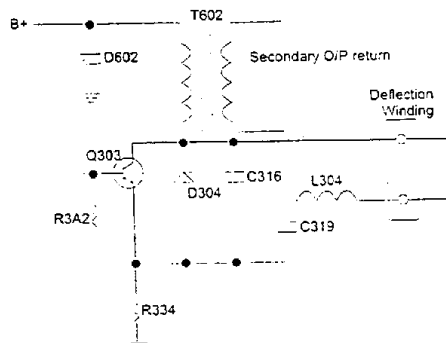

Figure 3-10 Basic Horizontal Deflection Output Circuit

The main inductance L is now divided into the primary winding of the Flyback Transformer (FBT) T602 and the deflection yoke winding. The deflection yoke is coupled through a capacitor C319, which has two function. Primarily it prevents DC unwanted DC currents

flowing through the deflection yoke which would otherwise cause an undesirable deflection of the CRT beam.

Secondly, the voltage drop across it due to the AC ramp current flowing causes a parabolic modulation in the slope of the ramp, leading to a progressive curve in the ramp, symmetrical about the zero current value as shown in Figure 3-11. This intentional distortion of the linear ramp is required to compensate for the 'S', or symmetric linearity distortion in the CRT.

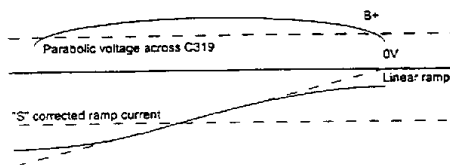

Figure 3-11 Linear Ramp Distortion

In series with C319 and the deflection yoke is another inductor, L304. This is a saturating inductor that is biased with a permanent magnet. Consequently this device has a linearity that is higher for current flow in one direction than in the opposite direction. This function provides compensation for resistive losses that would otherwise cause an undesirable exponential curve to the linear ramp, resulting in asymmetrical linearity errors in the displayed image.

The voltage seen in the output stage requires special attention. The B+ supply can vary between 60-180V. The main flyback pulse seen across Q303 and associated components is around 1100Vp. Consequently, appropriate precautionary measures must be taken when servicing the monitor.

In addition to the basic topology as described above, there are a number of other additional devices. Q306, Q307, Q330 and Q333 can be independently turned on or off under logic control. These devices switch addition capacitors, C320, C322, C362 and C367 in parallel with C319 to alter the amount of 'S' correction at different horizontal scan frequencies.

D308 and D309 acts as a constant current source that can be under SW301 and SW302 control. This current source drives an adjustable constant current into L304. This current flows into the deflection yoke and adds a variable DC offset to allow image raster centering to be achieved.

The B+ provides current for the deflection coil (D/Y). Therefore, changes in deflection current can be controlled by modifying B+ voltage. As a result, horizontal width can be modified. In

order to obtain the side horizontal width different frequencies, a DC to DC feed circuit is added. The synchronization signal comes from deflection output, from between C380 and C381 to base of Q603 which drives Q604 to trigger pin 4 of IC601. Feedback signal comes from secondary on T601, via D604, D605 and R611 to become a DC voltage on pin 1 of IC601, another feedback signal passes through the emitter of Q303, via R606 on pin 3 of IC601. These signals determine duty cycle of output signal of IC601 which is coupled to T601 drive Q601, to control B+, making it possible to have correct deflection current and horizontal width on different frequencies. Similarly output pin 36 and pin 37 of IC801 drive through R368, C348, R369, R366, C347, R367 and R610 to control duty cycle of IC601 output to achieve horizontal width adjustment.

During mode change, the B+ supply can be instantly turned off by pulling up the amplifier input on pin 1 of IC601. This can be achieved by Q602, Q606 and Q605 which are driven from the logic circuit pin 9 of IC601 (MUTE). Whilst Q602, Q606 and Q605 switch off the B+ supply almost instantly, time taken for the supply to restart is programmed by the value of logic circuit.

In addition, the B+ (215V) supply is configured so as to maintain a constant anode voltage. The anode voltage is derived from the flyback transformer T103. As the flyback voltage across primary is already a high voltage pulse around 680Vp, it requires only a modest ratio to step this pulse up to around 27kV working voltage of the CRT. Refer to the schematic of the major components in Figure 3-12.

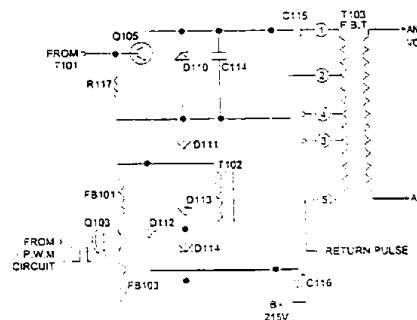

Figure 3-12 Basic High Voltage Output Circuit

The flyback pulse at the primary of T103 is proportional to the both frequency and the supply rail B+. In order to maintain the anode voltage at a constant 27kV a regulation system

is required. This is achieved using a PWM regulation stage formed by a IC101 driving a Q103. The causes a regulating current on primary T102, the voltage changes in secondary T102 result in a constant high voltage, synchronized by the horizontal oscillator. The IC101 has an error amplifier that generates an error signal from the feedback network formed by the high voltage bleed resistor and capacitor (it is internal to T103). Resistors VR101, R103 and R104 set the DC feedback ratio, and by adjustment of VR101, this ratio can be adjusted at setup to set the high voltage at it's nominal value of 27kV. The AC frequency response of the serve loop is set by C104 and R114 for optimum stability and relegation characteristics.

The output of the error amplifier which can be observed on pin 1 of IC101 is internally compared with a DC voltage. This DC is produced across.

The average beam current through the CRT also flows through the secondary high voltage winding of T103 connected to pin 8 of T103. C132 and R138 smooths the pulse of current flowing in the secondary winding and the average DC current is supplies through a variable resistor VR106. When the average secondary current flowing exceed 460mA, this voltage begins to drop below this threshold. Thus a signal is generated which can be fed to video amplifier for automatic beam current limiting (ABL).

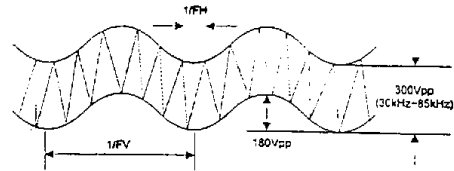

Figure 3-13 Focus Correction Wave

- For frequencies 69.5-86kHz, Q307, Q330, Q333 and RL301 are OFF, so CS is only C319, but L304 and L305 are in parallel.
- For frequencies 55-69kHz, Q307, Q333 and RL301 are OFF, Q330 is ON, so CS are C319 and C362 in parallel, but L304 and L305 are in parallel.
- For frequencies 45-55kHz, RL301 and Q333 are OFF, Q307 and Q330 are ON, so CS are C322, C362 and C319 in parallel, but L304 and L305 are in parallel.
- For frequencies 41-45kHz, Q330 and Q333 are OFF, Q307 and RL301 are ON, so CS are C322, C320 and C319 in parallel, but linear coil is only L304.
- For frequencies 36-41kHz, Q333 is OFF, Q307, Q330 and RL301 are ON, so CS are C320, C322 C362 and C319 in parallel, but linear coil is only L304.
- For frequencies 30-36kHz, Q307, Q330, Q333 and RL301 are ON, so CS are C320, C322 C362, C367 and C319 in parallel, but linear coil is only L304.

3.2.8. X-RAY Protection Circuit

The feedback pulse voltage from T103 F.B.T is regulated through D302 to obtain a DC voltage and the appropriate set voltage is distributed by R323 and R324. When the feedback pulse voltage exceeds the set voltage, a DC voltage develops in the cathode of ZD302 which turns on Q304 and Q305. As a result, the pin 1 of IC306 (adj-pin) to 0V, so IC306 is turned off, putting the 12V is not output. This is the phenomenon of high voltage protection.

3.2.9. The Focus Circuit

The output waveform come from pin 16 of IC302 through C122 and R123 to the amplifier Q106, via T104 with horizontal waveform to modulation. After, the wave coupling of the T103 which make the focus performance on the C.R.T. This is waveform shown in figure 3-13.

3.2.10. Horizontal linearity and CS Switching

Switching CS is necessary to ensure the lines are in accordance with the specifications in multi-sync monitors.

Truth Table of Frequency Discriminator						
FREQ CS	30-36 kHz	36-41 kHz	41-45 kHz	45-55 kHz	55-69.5 kHz	69.5-86 kHz
CS1	L	L	L	H	H	H
CS2	L	L	L	L	H	H
CS3	L	L	H	L	L	H
CS4	L	H	H	H	H	H

Truth Table of Power Saving Detector						
Mode	H-sync	V-sync	PMG1	PMG3	Mute	Blanking
ON	Pulse	Pulse	1	0	0	0
Standby	No Pulse	Pulse	1	1	1	1
Suspend	Pulse	No Pulse	0	1	1	1
OFF	No Pulse	No Pulse	0	1	1	1

3.3. Video Amplifier

The RGB video and sync signals are supplied through a video cable directly to the Video Board at connector P1. The RGB

signals are terminated in 75 ohms by R1 and R31, R50 and R51.

The RGB signals then enter an IC3 LM1205 video pre-amplifier, providing synchronous black level clamping, variable picture contrast (gain) and RGB gain balance for alignment. Separate gain control voltages for the three pre-amplifier channels are provided via R67, R47 and R17 from the IC5 TDA8444 DAC which is loaded by the microcontroller via the I2C bus. These inputs enable the individual gains of each channel to be varied to allow channel gain balance. In addition, a common signal is applied on pin12 of IC3 to adjust all three channels by the same amount, to allow for overall gain or contrast control.

A synchronous clamping signal is derived from the horizontal sync pulse by Q2. This takes the trailing edge of the horizontal sync pulse, differentiates it through C74 and R86, which is applied pin 14 of IC3. The timing is shown in Figure 3-14.

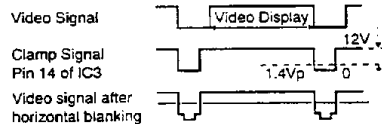

NOTE:
 A. Clamp signal is generated from horizontal sync pulse time.
 B. When the Clamp signal is less than 1.4Vp-p, the IC's internal clamp loop will operate; when greater than 1.4Vp-p, it will not operate.

Figure 3-14 Timing of Pin 14 Clamp Signal

The outputs of the video pre-amplifier are fed to IC1, a hybrid power amplifier IC type VPS10S, through resistors R56, R36 and R6. In addition, on screen display video information generated by IC1 can be injected via Q5, Q6, Q7, R3, R33, R53, D83, D84 and D85 through pin 2, pin 7 and pin 11 of IC1.

IC1 amplifies the video signals to around 40Vp-p. The outputs are AC coupled to the CRT cathodes via C5, C35 and C55. In order to bias the DC level of the cathodes correctly, the AC coupled signal is DC restored by clamping to a DC voltage which can be varied under microprocessor control. Considering Red channel output on IC1 as an example, the signal is clamped by D4 to the voltage set by the transistor amplifiers formed by Q3, which amplify the adjustable voltage at the output of the DAC. A similar stage can be seen for the green and blue channel outputs.

When the RC video signal amplification circuit is added for amplification, this waveform will change as shown in Figure 3-15 (a). Without the DC component, as shown in Figure 3-15 (b), the DC level of darker and brighter displays will be different, so when this kind of signal without a DC component is sent to the CRT, it will cause the contrast of the image to change as the signal changes. Therefore Q3, Q33, Q53, D4, D34 and D54 serve as a DC clamp and the CRT's cathodes DC voltage can be adjusted by the pin 10, pin 11, pin 12 of IC5 TDA8444 DAC.

IC2 is an On Screen Display processor. This is a simple video generation IC2 that has its own oscillator circuit. The oscillator circuit by using an internal Phase Locked Loop (PLL) the

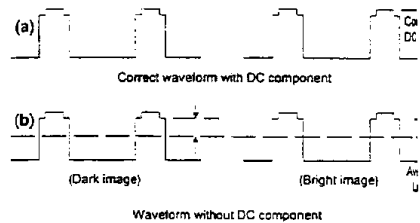

Figure 3-15 The Post Output Amplifier Circuit

IC2 can sync to the incoming vertical and horizontal oscill frequencies and produce the OSD video signals once initialized and loaded by the commands and data received on I2C bus. When the OSD display is activated, the blank output of the IC2 also sends a signal to the blanking input of IC3 (pin 13) to provide an optional black background for OSD display.

The RGB signals are amplified to drive the CRT by an VPS10S hybrid amplifier and capacitively coupled to cathodes.

Brightness control is achieved by varying the bias of the CRT via a transistor stage formed by Q111 which is driven by an output of the pin 9 of IC5. Vertical blanking signals is coupled into this amplifier Q204, Q205 and Q206 to prevent visible retrace lines.

3.4. Microprocessor And Sync Processing

The microprocessor is a MC68HC705BD3P type. It is particularly suitable as multisync computer monitor controller. This 8-bit microcontroller unit (MCU) contains an on-chip oscillator, CPU, RAM, ROM, M-Bus serial interface system (IIC), parallel I/O, Pulse Width Modulator, Multi-Func Timer and sync Signal Processor. It has a 7.75k bytes of ROM and 256 bytes of RAM on internal which contains a boot communication 'boot' routine and various other simple routines. It is also used to store the OSD icon bit map. The firmware routines and variable data stored in the 16k external EEROM, IC802.

When the micro is instructed via the IC2 bus, the internal ROM boot routine will load up the EEROM with program data from the IC2 bus. Thus it can be made to load its firmware. From then on it will run jointly out of EEROM and internal ROM. Another important routine within the internal ROM is the routine which allows data writes to be made to the EEROM. This must be resident in the micro as it can run from the EEROM whilst writing data. These control addressing and I/O port selection from the micro CPU is IC801 (MC68HC705BD3P).

Also specialized ports Pin16, Pin17 and Pin18 of IC801 form the M-Bus interface which is used internally to set the default value and the OSD IC and CS table control IC (IC803). In other way, specialized ports pin 11 and pin 12 of IC801 form the M-bus interface which is used internally to set the default value and the external EEROM IC802. In addition, the I/O ports from

19 to pin 23 of IC801 from the M-bus interface which is used internally to set the front panel control.

There are 16 PWM channels. Channel 0 to channel 7 are dedicated PWM channels while channel 8 to channel 15 are shared with ports C under the control of the corresponding configuration register. Thus it can be made to control H-PHASE, PARALLELOGRM, PIN-BALANCE, TRAPEZOID, PINCUSHION, TILT, V-SIZE, H-SIZE and V-POSITION on the pin 1, pin 26, pin 27, pin 28, pin 29, pin 34, pin 35, pin 36, pin 37 and pin 38 of IC801.

The micro also drives the sync selection circuits. IC801 is used to set the polarity of the incoming sync signals and allows the micro to sample the vertical and horizontal syncs and to select the correct polarity on the outputs H-SYNC and V-SYNC appropriately. In addition, whilst sampling the polarity, the micro can measure the frequency of both syncs. By suitable selection of H-SYNC and V-SYNC control lines, it does this when ever a mode change occurs. A mode change is detected by either a change in vertical frequency, which is monitored by firmware, or by a sudden change in horizontal frequency.

When power is disturbed to the unit, the power reset line goes low. This also causes an input to the micro via the MODEC line. On detecting this interrupt, the micro first checks inputs Pin 4 of IC801. If these are also low, then it knows the MODEC interrupt was caused by an impending power failure. In this case the micro saves the current RAM data in EEROM and prepares for power off. The RESET line is delayed for 7ms by R801, ZD801, R803 and C301 to allow time for the data to be saved. The REST line then holds off the micro and the EEROM until power is good once more.

Section 4.

Setup Adjustments

4.1.	Preparing the Display for Adjustment	4-1
4.2.	Adjustment Procedures	4-1
4.3.	High Voltage Verification	4-2
4.4.	X-ray Protection Check	4-2
4.5.	G1 Voltage Adjustment	4-2
4.6.	Background Brightness Setting	4-2
4.7.	Screen Brightness Adjustment	4-2
4.8.	Magnetic Field Configuration	4-3
4.9.	Raster Center Verification	4-3
4.10.	Tilt Verification	4-3
4.11.	Focus Verification	4-3
4.12.	Color Misconvergence	4-3
4.13.	Primary Test Mode Performance Adjustment	4-3
4.14.	Performance Adjustments for All Preset Mode	4-3
4.15.	Image Performance Verifications	4-4
4.16.	Uniformity Verification	4-4
4.17.	Brightness Verification	4-4
4.18.	Display Size Stability	4-4
4.19.	Color Purity Verification	4-4
4.20.	Video Noise	4-4
4.21.	Power Saving Check	4-4
4.22.	DDC 1/2 Data Wiring	4-4

4.1. Preparing the Display for Adjustment

Before adjusting any the display settings or making final adjustments after service, perform the following pre-test settings to prepare the display for adjustment:

1. Be sure to allow the display to warm up for at least 30 minutes before making any adjustments.
2. When making tests and adjustments, the CRT should be facing east or west to minimize the affect of the earth's magnetic field.
3. Set the contrast control at 80% and the brightness control at 50% for all tests unless otherwise specified.
4. Thoroughly degauss the entire screen with a manual degausser before proceeding with tests.
5. All test should be performed with the rated power supply voltage unless otherwise specified.

4.1.1. Test Equipment Required

The following equipment will be required to make the tests and adjustments detailed in this section:

- Video signal and pattern generator
- Digital multimeter
- Degausser

4.2. Adjustment Procedures

4.2.1. Adjustment Sequence

This display undergoes an automatic alignment procedure during manufacture. This alignment procedure follows a fixed sequence of adjustments which duplicated in this section. When making manual adjustments during service, you should always make adjustments in the order given here to ensure correct results.

4.2.2. Preset Timings Used During Adjustment

During alignment it is necessary to input certain timings stored in the display. The detailed parameters of all the preset timings are given in the table below your reference.

IMPORTANT NOTE

The preset timings for different versions of this model may differ from those shown here. Be sure to check the list of preset timings for the unit being serviced.

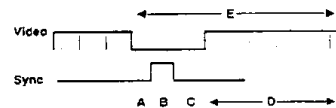

Mode Number	Mode 1	Mode 2	Mode 3	Mode 4	Mode 5	Mode 6	Mode 7	Mode 8	Mode 9	Mode 10	Mode 11
Data Pixel	1600	1280	1152	1280	1024	1024	832	800	640	640	640
Data Line	1200	1024	870	1024	768	768	624	600	480	480	480
H. Freq.(kHz)	81.250	79.976	68.680	63.981	60.241	60.023	49.725	46.875	37.500	31.469	31.469
V. Freq(Hz)	65.000	75.025	75.060	60.020	74.927	75.029	74.550	75.000	75.000	59.942	59.942
Pixel Rate(MHz)	175.500	135.000	100.000	108.000	80.000	78.750	57.280	49.500	31.500	25.175	25.175
Hor. FP μ s(A)	0.365	0.119	0.320	0.444	0.400	0.203	0.559	0.323	0.508	0.636	0.636
Hor. Sync μ s(B)	1.094	1.067	1.280	1.037	1.200	1.219	1.117	1.616	2.032	3.813	3.813
Hor. BP μ s(C)	1.732	1.837	1.440	2.296	2.200	2.235	3.910	3.232	3.810	1.907	1.907
Hor. Active μ s(D)	9.117	9.481	11.520	11.852	12.800	13.003	14.524	16.162	20.317	25.422	25.422
Hor. Total μ s(E)	12.308	12.504	14.560	15.630	16.600	16.660	20.111	21.333	26.667	31.778	31.778
Ver. FP ms(A)	0.012	0.013	0.044	0.016	0.050	0.017	0.020	0.021	0.027	0.318	0.318
Ver. Sync ms(B)	0.037	0.038	0.044	0.047	0.050	0.050	0.060	0.064	0.080	0.054	0.054
Ver. BP ms(C)	0.566	0.475	0.568	0.594	0.498	0.466	0.784	0.448	0.427	1.048	1.048
Ver. Active ms(D)	14.769	12.804	12.667	16.005	12.749	12.795	12.549	12.800	12.800	15.253	15.253
Ver. Total ms(E)	15.385	13.329	13.322	16.661	13.347	13.328	13.413	13.333	13.333	16.683	16.683
Polarity(H.V)	+,+	+,+	-,-	+,+	-,-	+,+	-,-	+,+	-,-	-,-	-,-
Primary mode is 60.023kHz / 75.029Hz (1024x768)											

Table 4-1 Table of preset Timing Parameters

IMPORTANT NOTE

The adjustment settings in this section are based on REVISION B of the factory alignment procedures. Appendices detailing changes in the factory alignment procedures that have occurred since publication of this service manual are available upon request.

Initial settings to be carried out manually prior to automatic alignment:

4.3. High Voltage Verification

1. Input a cross hatch pattern in 81.25kHz (1600X1200) mode and adjust VR101 on the main board (see figure 4-1 for approximate location) so the high voltage is in the range $27kV \pm 0.3$.
2. Input a full white pattern in 31.47kHz (640x480) mode, check that the high voltage is in the range $27kV \pm 0.3$.

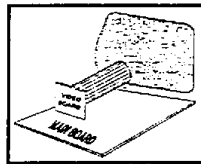

Location of PCBs

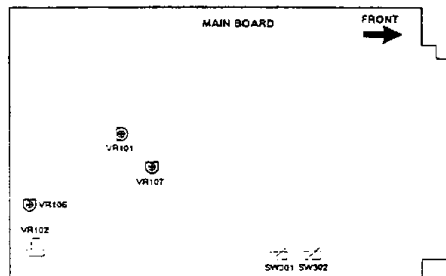

Figure 4-1 Location of on Main board

4.4. X-ray Protection Check

Input a cross hatch pattern in 81.25kHz (1600x1200) mode, and use the 560kΩ resistor in parallel R103, then the X-ray protection circuit shall be operation.

4.5. G1 Voltage Adjustment

Input a raster pattern (video OFF) in primary mode and push the external brightness control button to maximum. Adjust

VR102 (see Figure 4-1 for approximate location) so that the voltage of G1 read on a digital multimeter is $-45V \pm 1$.

Steps used in white balance adjustment:**4.6. Background Brightness Setting**

1. Input a raster pattern in primary mode and push the external brightness control button to maximum. Adjust the SCREEN VR so background brightness is approximately $1.0FL \pm 0.1$.
2. Before carrying out white balance adjustment, make sure that the display size and linearity are in spec.
3. Before carrying out white balance adjustment, make sure that the VR106 (see Figure 4-1 for approximate location) position shall be turn counterclockwise to the end (ABL no action).
4. Before carrying out white balance adjustment, make sure that the internal contrast VR107 (see Figure 4-1 for approximate location) shall be turn to the center position.
5. Input timing in primary mode, and the white balance automatic adjust some item as blow.
 - a) Input no video pattern in primary mode, and set-up brightness of raster white balance get the x,y value is $x=0.346 \pm 0.01$ $y=0.359 \pm 0.01$.
 - b) Input a full white pattern in primary mode, and set-up 5000 degrees kelvin of picture white balance get the x,y value is $x=0.346 \pm 0.01$ $y=0.359 \pm 0.01$.
 - c) Input a full white pattern in primary mode, and set-up 6500 degrees kelvin of picture white balance get the x,y value is $x=0.313 \pm 0.01$ $y=0.329 \pm 0.01$.
 - d) Input a full white pattern in primary mode, and set-up 9300 degrees kelvin of picture white balance get the x,y value is $x=0.281 \pm 0.01$ $y=0.311 \pm 0.01$.

4.7. Screen Brightness Adjustment

1. Input a raster pattern in primary mode. Set external brightness key to maximum and external contrast key to minimum, then make sure that the raster brightness range is $0.8FL \pm 0.2$. If not in this range, adjust screen VR of F.B.T.
2. Input a raster pattern (video off) in primary mode. Set external contrast key to maximum and push external brightness key to brightness is 0.08FL (cut OFF), then switch to a display of full white pattern and adjust internal contrast VR107 and check that brightness at the center of the screen is in the range $30FL \pm 1$.

3. Input a full white pattern in primary mode. Set external brightness and contrast key to maximum. Adjust VR106 and check that brightness at the center of the screen is in the range 35FL±1.

Conclusion White Balance Adjustment:

4.8. Magnetic Field Configuration

Configure the magnetic field as follows:

- Northern hemisphere : H=0.01, V=0.45
- Southern hemisphere : H=0.01, V=-0.52

4.9. Raster Center Verification

Input a cross hatch pattern in 81.25kHz (1600x1200) mode, and check raster H-Center shall be less than 3mm ($|L-R| \leq 3\text{mm}$). If not in this ranged and select SW301 for adjustment raster H-center shall be less than 3mm, if not in this ranged again, please select SW302 for adjustment raster H-center in the specification.

4.10. Tilt Verification

Input a cross hatch pattern in primary mode and use the tilt rotation key to ensure that tilt is less than 1mm.

4.11. Focus Verification

1. Input a full white pattern in primary mode. Use the external brightness control to adjust background brightness so it is not visible and set external contrast so the brightness is 28FL, then switch to a display of cross hatch pattern.
2. Adjust the FBT focus VR1 and VR2 so the vertical line and horizontal line are as clear as possible.
3. Input a "o" characters pattern in primary mode and check "o" characters is clearest.

4.12. Color Misconvergence

1. Input a full white pattern in primary mode and adjust external brightness so there is no background brightness and external contrast so the screen brightness is 28FL.
2. Switch to a cross hatch pattern and verify that misconvergence in a circle measured from the center of the screen (Area A) is not greater than 0.3mm, and for all areas outside Area A is not greater than 0.4mm.
3. If not in the specification, after used the magnetic in a four corner adjustments for arrive to better color convergence.

Automatic camera alignment procedure:

The procedures listed below are those carried out using automatic Camera Alignment System (CAS). These adjustments cannot be made manually but must be performed using the CAS software provided by the manufacturer.

4.13. Primary Test Mode Performance Adjustments

1. **V. RASTER CENTERING**
Raster area centered vertically in the bezel.
2. **ROTATION (TILT)**
Raster area aligned with bezel.

4.14. Performance Adjustments for All Preset Modes

1. **H POSITION**
Centers the picture display horizontally in the bezel ($|L-R| \leq 1\text{mm}$).
2. **H SIZE**
Configures picture display width as $360 \pm 2\text{mm}$.
3. **V POSITION**
Centers the picture display vertically in the bezel ($|T-B| \leq 1\text{mm}$).
4. **V SIZE**
Configures picture display height as $270 \pm 2\text{mm}$.
5. **V Linearity**
Configures vertical linearity as less than 8% (primary mode is 6%).
6. **Rotation**
Configures picture display rotation as less than 1mm.
7. **Pin-Balance**
Sets left and right pin-balance distortion to less than 1.5mm.
8. **PINCUSHION**
Sets left and right pincushion distortion to less than 1.5mm.
9. **Trapezium**
Sets upper and lower trapezium distortion to less than 1.5mm.
10. **Parallelogram**
Sets parallelogram distortion to less than 1.5mm.

Conclusion of automatic alignment:

4.15. Image Performance Verification

Input each of the preset timings and check that the following specifications are met:

1. **Horizontal Position**

$$|L-R| \leq 3\text{mm}$$

2. **Horizontal Size**

$$360 \pm 3\text{mm}$$

3. **Vertical Position**

$$|T-B| \leq 3\text{mm}$$

4. **Vertical Size**

$$270 \pm 3\text{mm}$$

5. **Horizontal Linearity**

$$H \leq 10\% \text{ (10 x 8 cross hatch pattern)}$$

This calculation is based on the following formula:

$$\frac{Max - Min}{Max} \times 100\% \leq 10\% \text{ (primary mode is 8\%)}$$

6. **Vertical Linearity**

$$V \leq 8.0\% \text{ (10x8 cross hatch pattern)}$$

$$\frac{Max - Min}{Max} \times 100\% \leq 8\% \text{ (primary mode is 6\%)}$$

7. **Geometric Edge Distortion**

All geometrics distortion shall be less than as below:

Horizontal line $\leq 2\text{mm}$

Vertical line $\leq 2\text{mm}$

8. **Recall Button Function**

Adjust H/V phase and size at random using the external controls and press the recall button. Check that the image performance has returned to be in spec, which will indicate the recall button is functioning correctly.

4.16. Uniformity Verification

Input a full white pattern in primary mode, set contrast to maximum and check that there is no overshoot. Check that the brightness in the four corners of the screen is not less than 70% of that in the center of the screen.

4.17. Brightness Verification

1. Input a raster pattern (no video pattern) in primary mode. Adjust external brightness to maximum and measure the center of raster brightness is between 0.5 to 2.5FL.
2. Input a raster pattern (no video pattern) in primary mode. Adjust external brightness to 0.08FL (cut off).
3. Input a full white pattern and adjust external contrast to maximum then check that brightness at the center of the screen shall be more than 28FL. Adjust external brightness to maximum and check that brightness at the center of the screen is less than 40FL.

4.18. Display Size Stability

Input a full white pattern in primary mode, set external brightness at 5FL and measure the display size. Adjust the brightness to 30FL and remeasure the display size. The difference should be less than 0.8mm.

4.19. Color Purity Verification

1. Input a full white pattern in primary mode and adjust external brightness so there is no background brightness and adjust external contrast to 25FL. Make a visual check of color purity as follows:
 - a) Input the red (R) signal only; no green (G) or blue (B) should be visible.
 - b) Input the (G) signal only; no (R) or B should be visible.
 - c) Input the (B) signal only; no (R) or (G) should be visible.

4.20. Video Noise

Input a cross hatch pattern or full white pattern in primary mode and make a visual check from a distance of 48.3cm (19 inches) for any video noise or other on-screen interference.

4.21. Power Saving Check

1. Input cross hatch pattern in primary mode.
2. Turn OFF H-Sync signal, the power indicator LED have to change the emitting color from green to orange, then turn ON H-Sync signal again, the picture shall be visible.
3. Turn OFF V-Sync signal, the power indicator LED have to change the emitting color from green to orange, then turn ON V-Sync signal again, the picture shall be visible.
4. Turn OFF H/V-Sync signal, the power indicator LED have to change the emitting color from green to orange, then turn ON H/V-Sync signal again, the picture shall be visible.

4.22. DDC 1/2 Data Writing

Writing the DDC 1/2 data in EEROM.

Section 5.

Troubleshooting

5.1.	No Display at Power-on	5-1
5.2.	No X-ray Operation	5-2
5.3.	No Video Operation	5-3
5.4.	Poor Vertical Linearity	5-4
5.5.	Poor Horizontal Linearity	5-5
5.6.	Poor Uniformity	5-6
5.7.	Tilted Display Area	5-7
5.8.	Misconvergence	5-8
5.9.	Poor Regulation	5-9
5.10.	Poor Focus	5-10
5.11.	Poor Geometry Distortion	5-11

5.1. No Display at Power-on

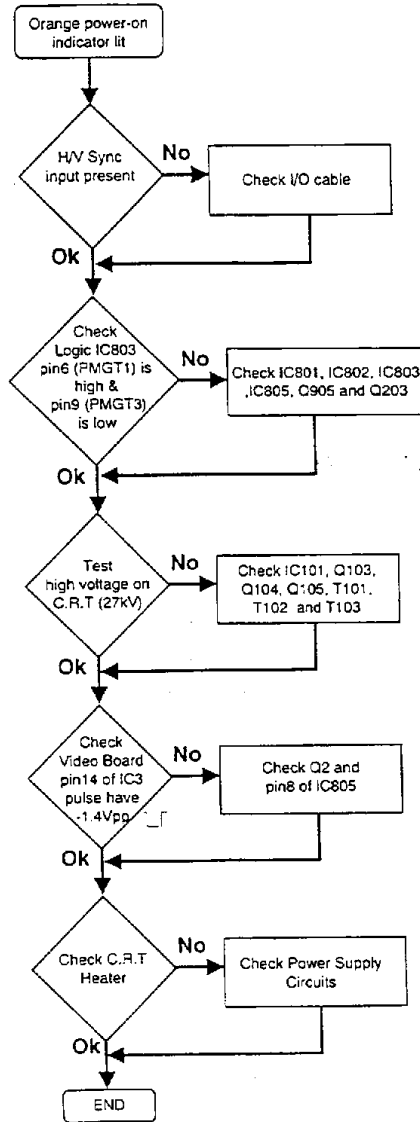

5.2. No X-ray Operation

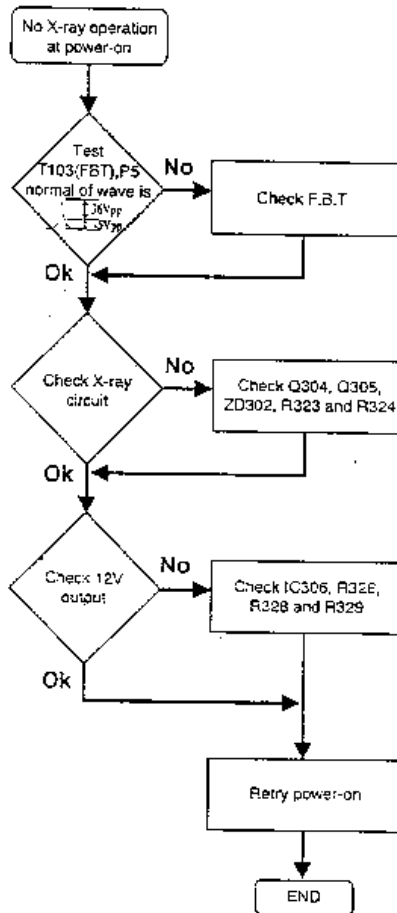

5.3. No Video Operation

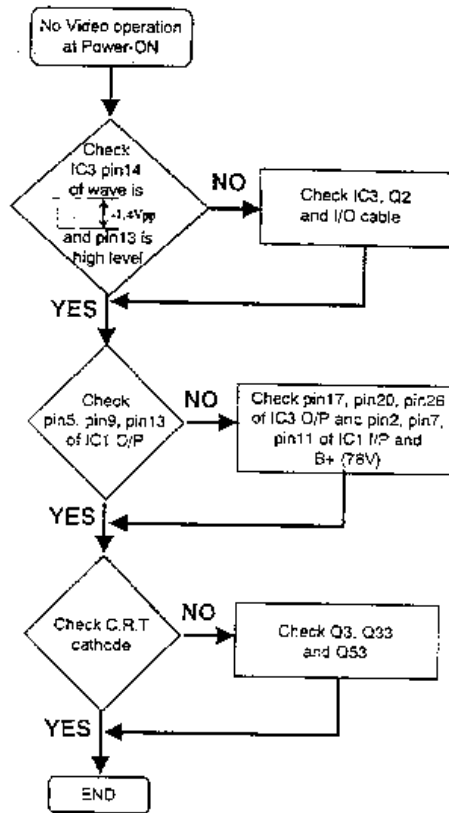

5.4. Poor Vertical Linearity

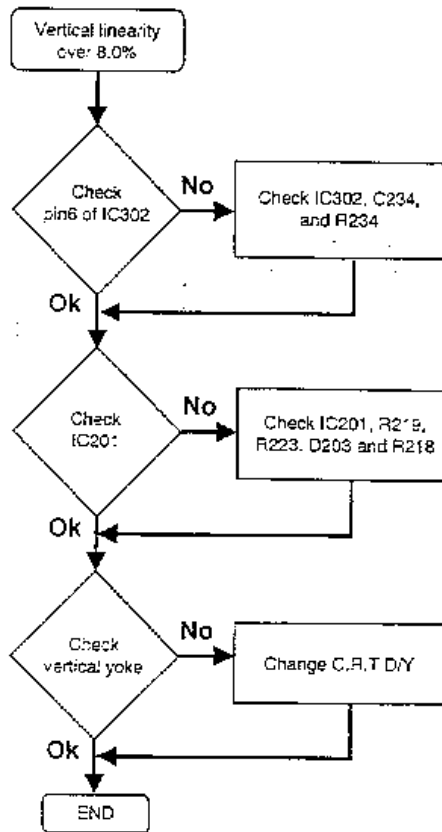

5.5. Poor Horizontal Linearity

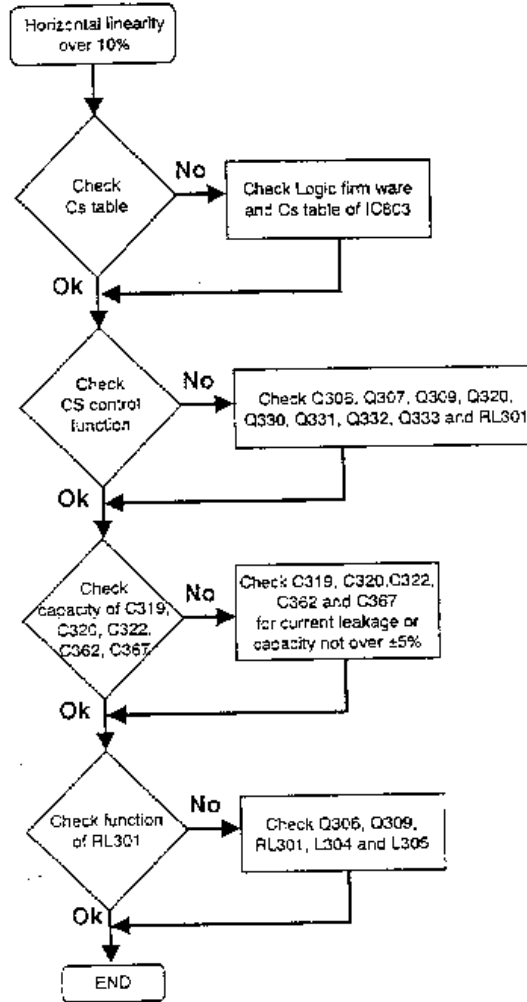

5.6. Poor Uniformity

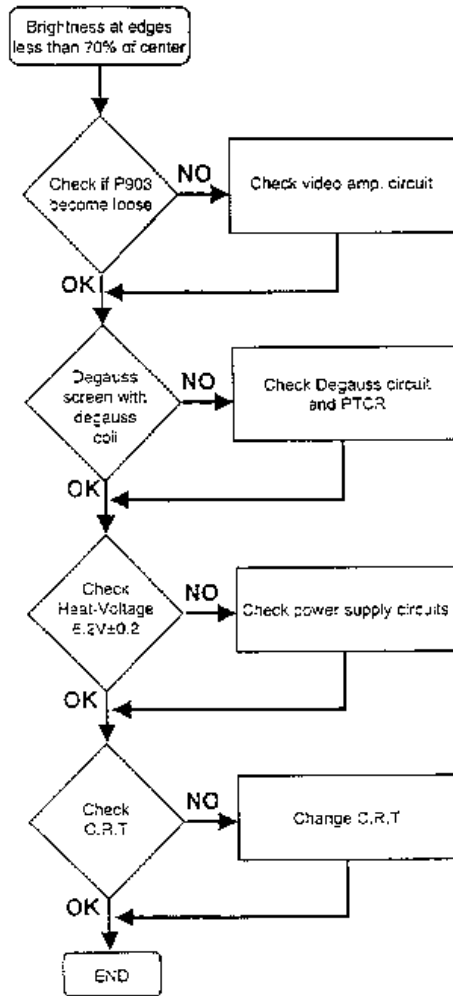

5.7. Tilted Display Area

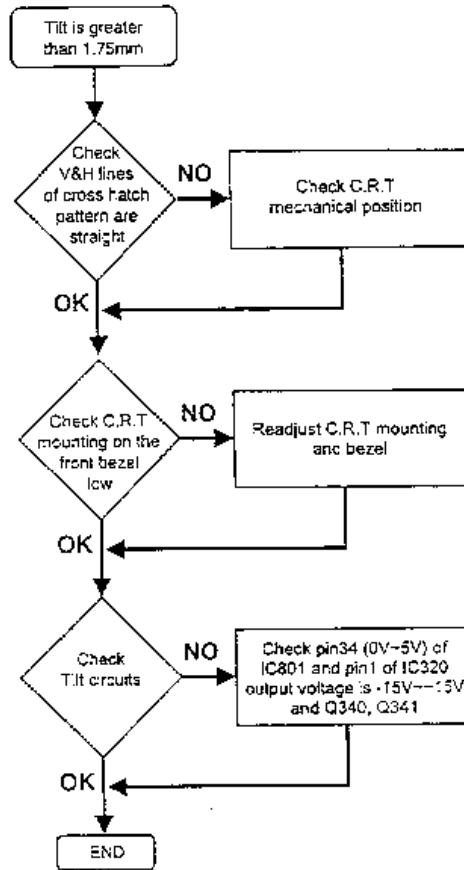

5.8. Misconvergence

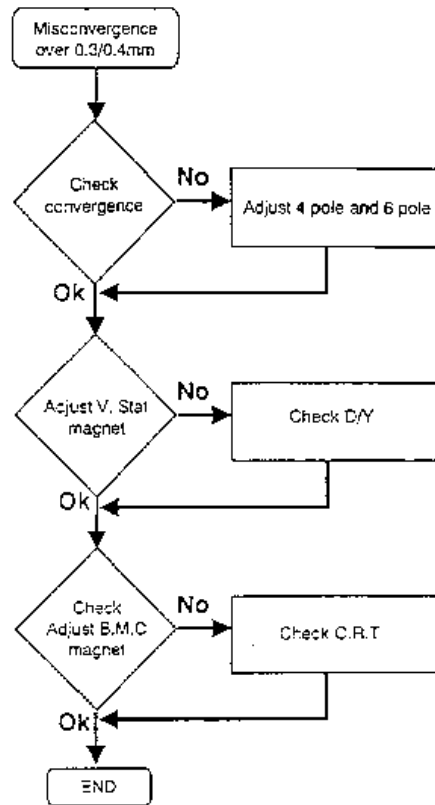

5.9. Poor Regulation

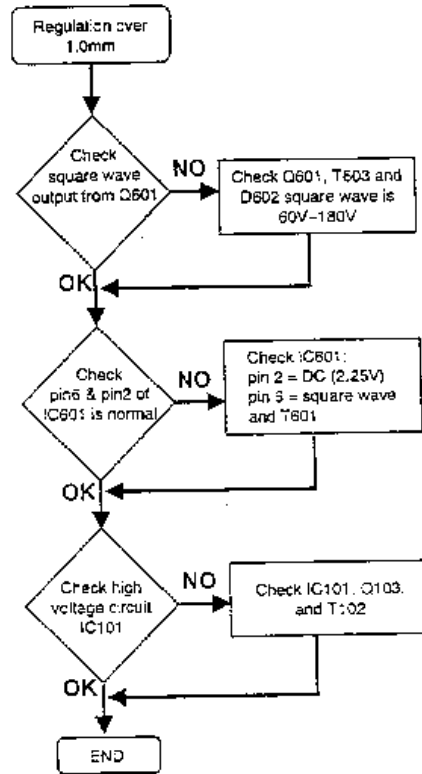

5.10. Poor Focus

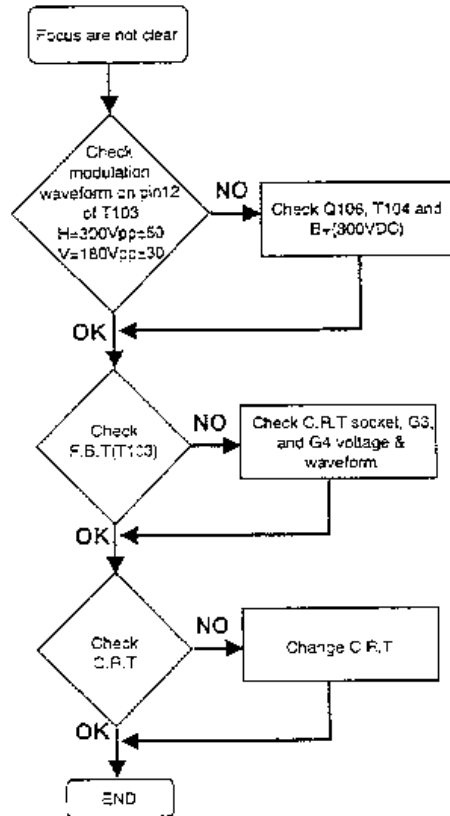

5.11. Poor Geometry Distortion

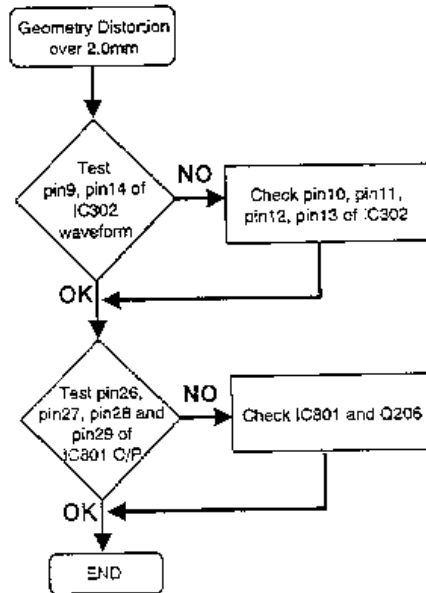

Section 6.

Printed Circuit Boards

6.1.	Neck Board	6-1
6.2.	Main Board	6-2
6.3.	Control Board	6-3
6.4.	PCB Wiring Connection	6-3

6.2. Main Board

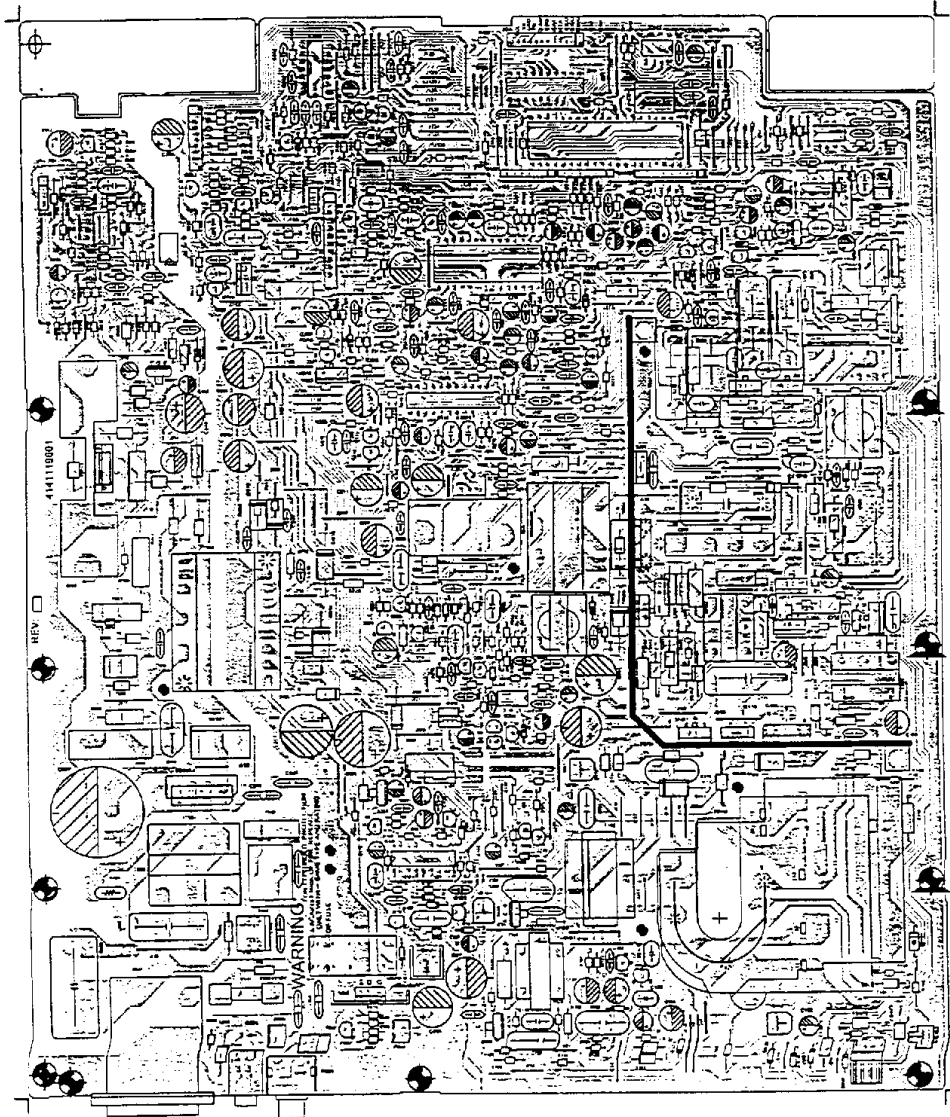

Figure 6-2 Main Board (Solder Side)

6.3. Control Board

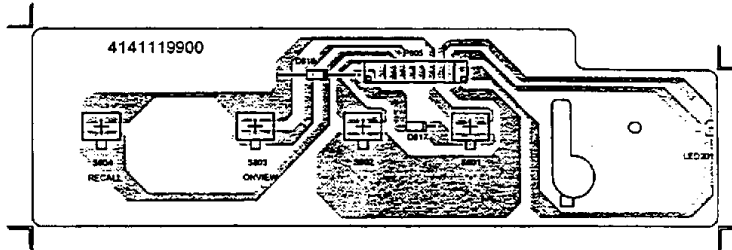

Figure 6-3 Control Board (Solder Side)

6.4. PCB Wiring Connection

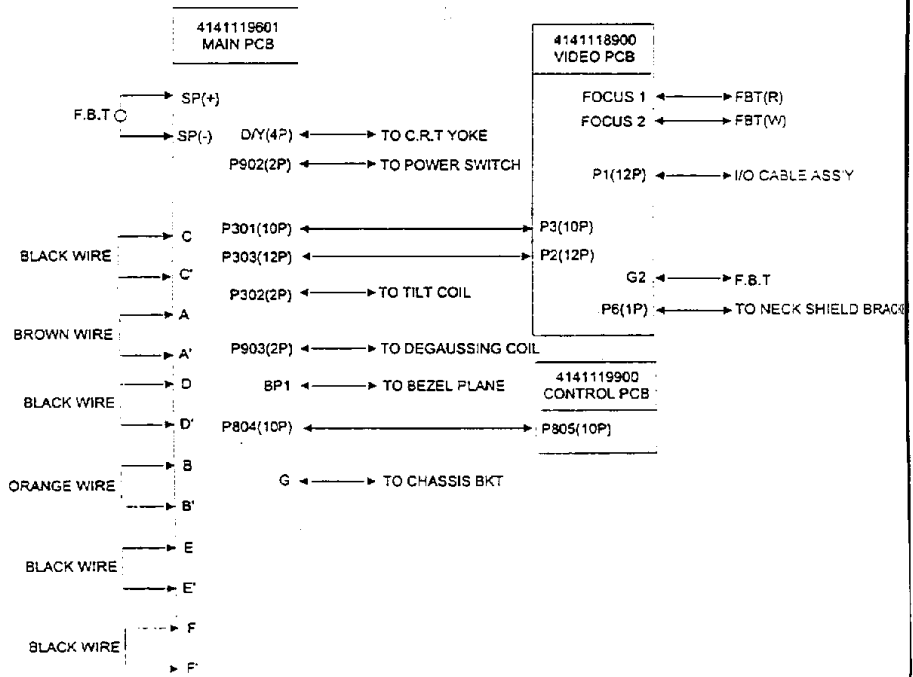

Figure 6-4 PCB Wiring Connection

6.1. Neck Board

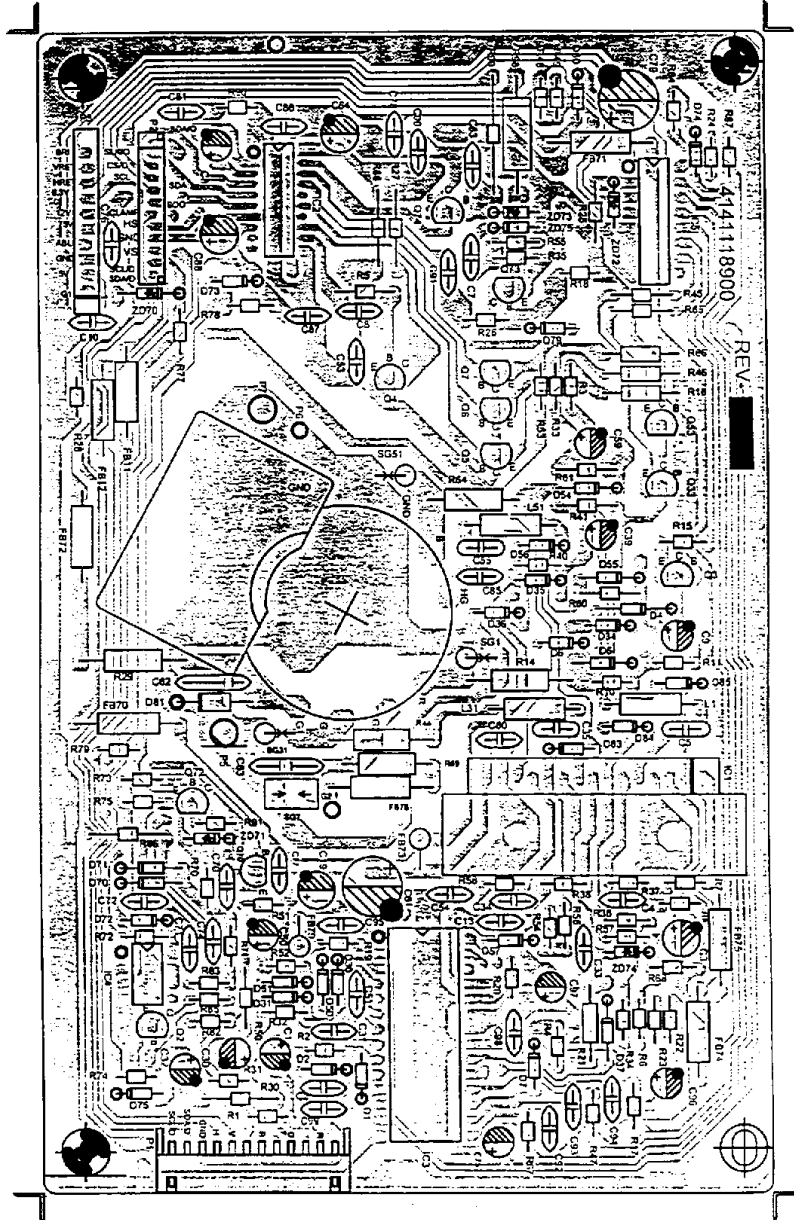

Figure 6-1 Neck Board (Solder Side)

Section 7.

Schematic Diagrams

7.1.	Neck Circuit Diagram	7-1
7.2.	SPS/Micro Controller/Deflection Circuit Diagram . . .	7-1

7.1. Neck Circuit Diagram

Please refer to the attached circuit diagram.

7.2. SPS/Micro Controller/Deflection Circuit Diagram

Please refer to the attached circuit diagram.

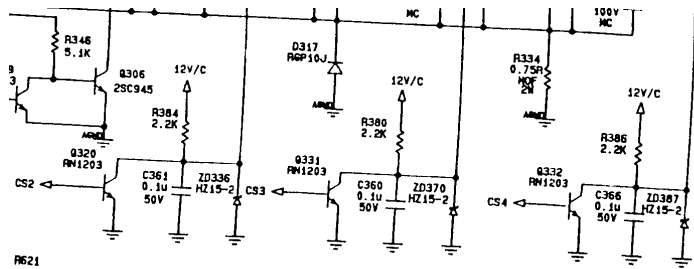

R621
5.1K

	30K-36K	36K-41K	41K-45K	45K-55K	55K-69.5K	69.5K-86K
CS1	L	L	L	H	H	H
CS2	L	L	L	L	H	H
CS3	L	L	H	L	L	H
CS4	L	H	H	H	H	H

	NOMAL ON	STAND-BY H-OFF/30 R	SUSPEND V-OFF V&H-OFF/R	MODEL CHANGE	POWER ON
PHG1	H1	H1	Lo	H1	H1
PHG3	Lo	H1	H1	Lo	
BLK	Lo	H1	H1		
MUTE	Lo	H1	H1		

TER

6mm TO RIGHT	4mm TO R	2mm TO R
RIGHT	RIGHT	RIGHT
RIGHT	CENTER	LEFT

SIMPLE OF DIRECTION

	LEFT				RIGHT		
mm	6	4	2	0	6	4	2
SW301	←	←	←	↑	→	→	→
SW302	→	↑	←	↑	→	↑	←

VIEWSONIC CORPORATION			
DRAWING DATE	TOLERANCE		SCALE
11-19-'96	DIM	ANGLE	/
	+	-	
DRAWER	DWGSET	DRAWING NAME	UNIT
	OF	ALL IN ONE	
MODEL: G800			

3 2 1

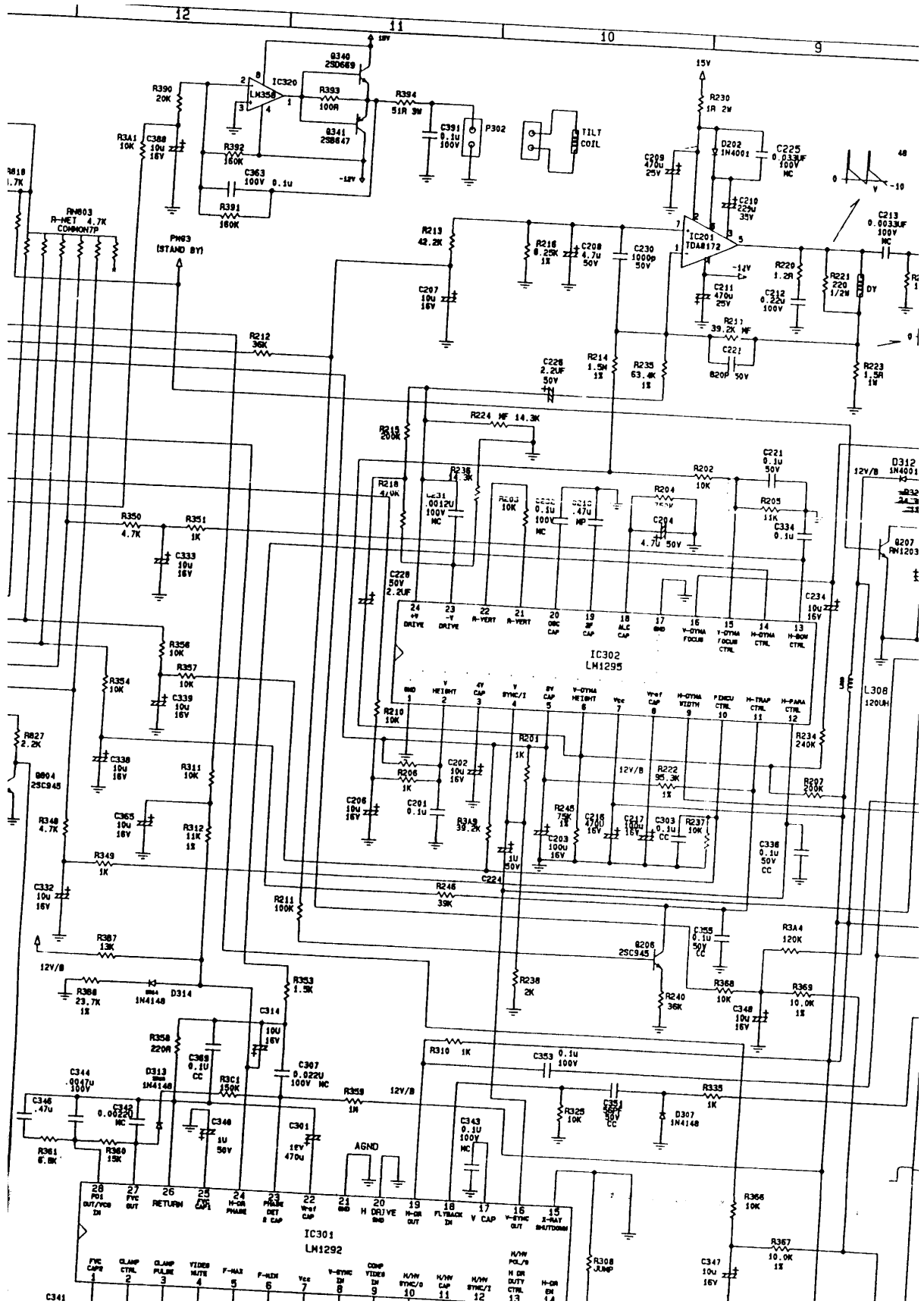

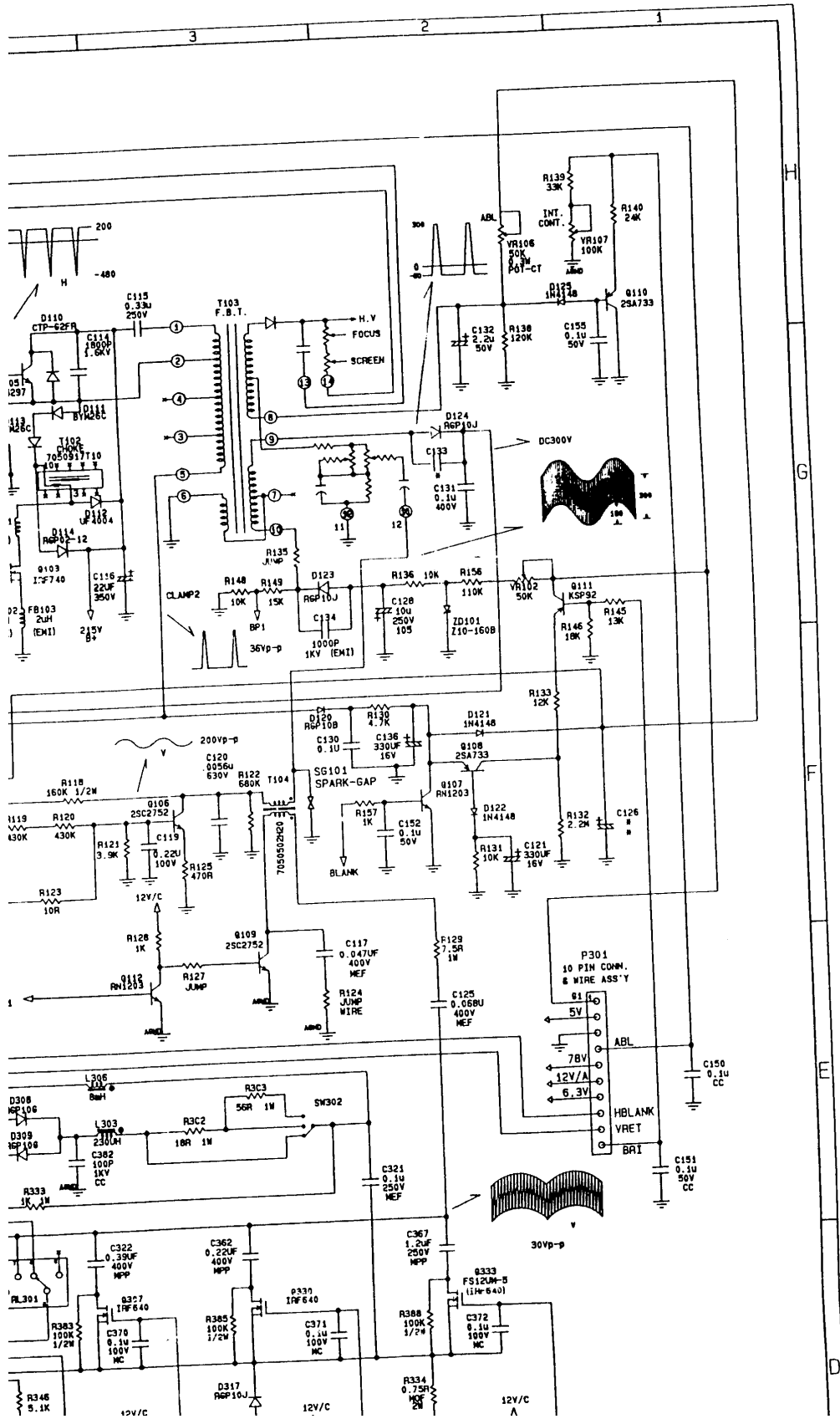

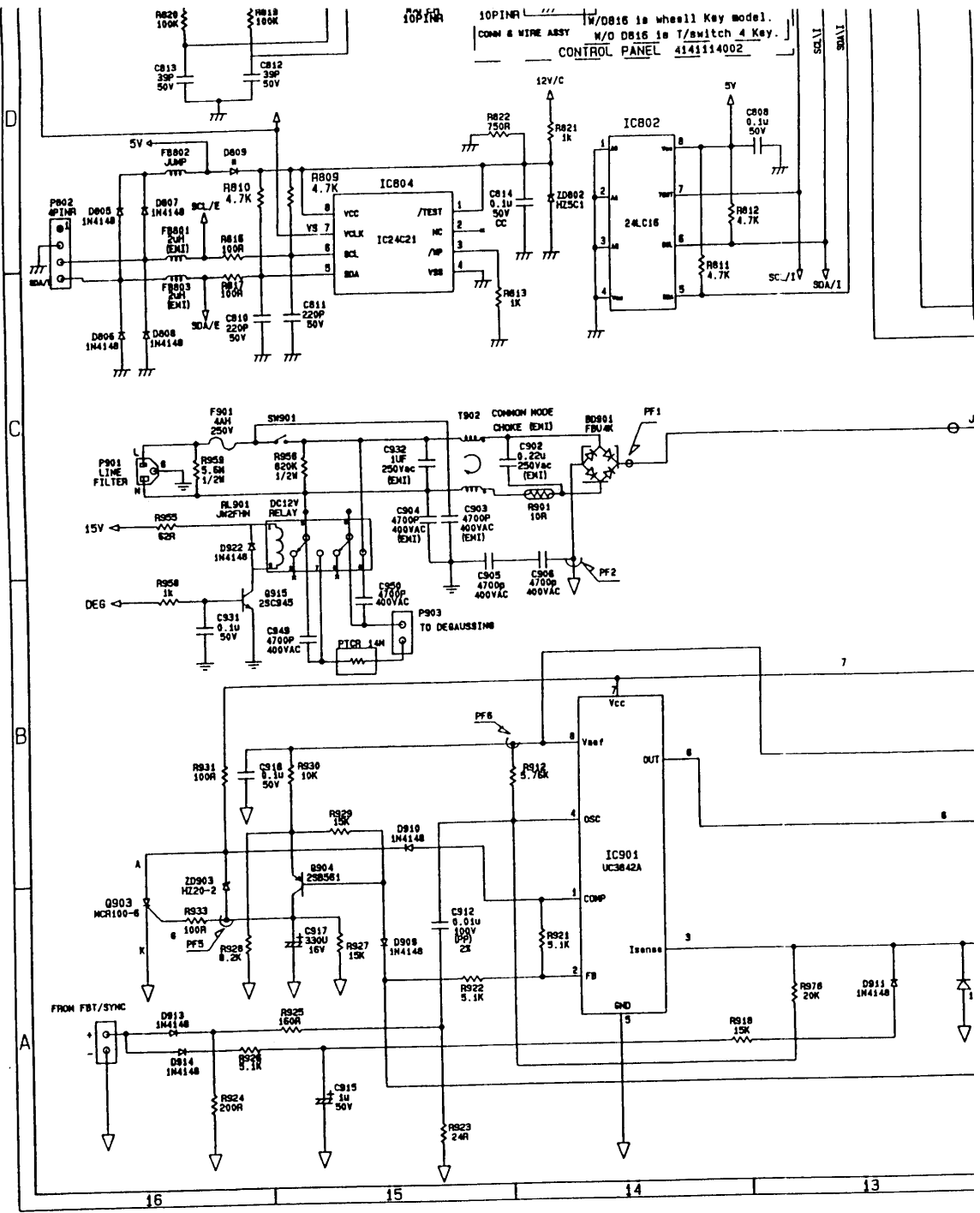

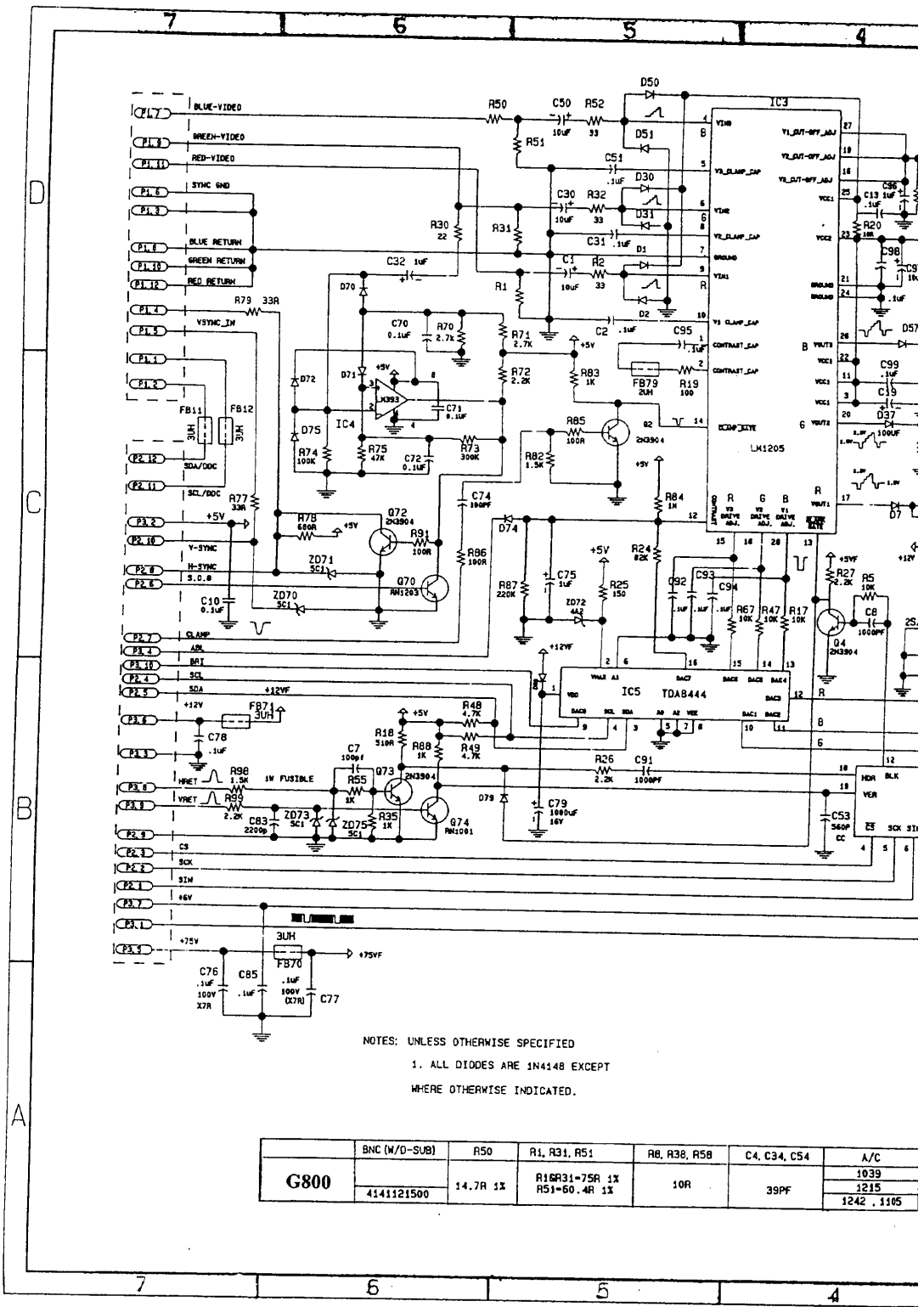

NOTES: UNLESS OTHERWISE SPECIFIED
 1. ALL DIODES ARE 1N4148 EXCEPT
 WHERE OTHERWISE INDICATED.

	BNC (M/D-SUB)	R50	R1, R31, R51	R8, R38, R58	C4, C34, C54	A/C
G800		14.7R 1X	R16R31=75R 1X R51=60.4R 1X	10R	39PF	1039
						1215
	4141121500					1242, 1105

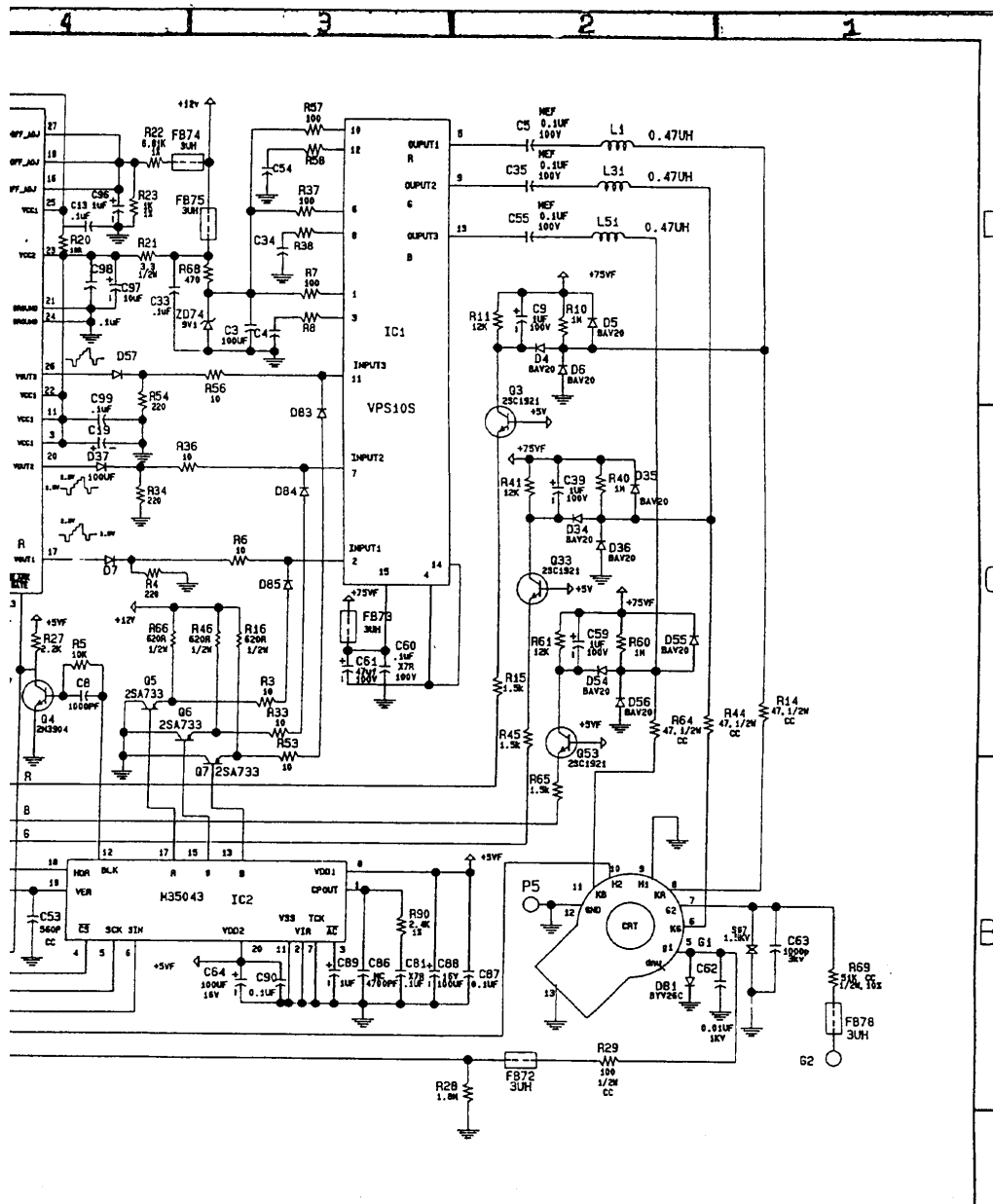

14	A/C
	1039
	1215
	1242, 1105

VIEWSONIC CORPORATION			
DRAWING DATE	TOLERANCE		SCALE
11-18-'96	DIM	ANGLE	/
	+	-	
DRAWER	SHEET	DRAWING NAME	FILE NAME
	OF	VIDEO	
MODEL: G800			

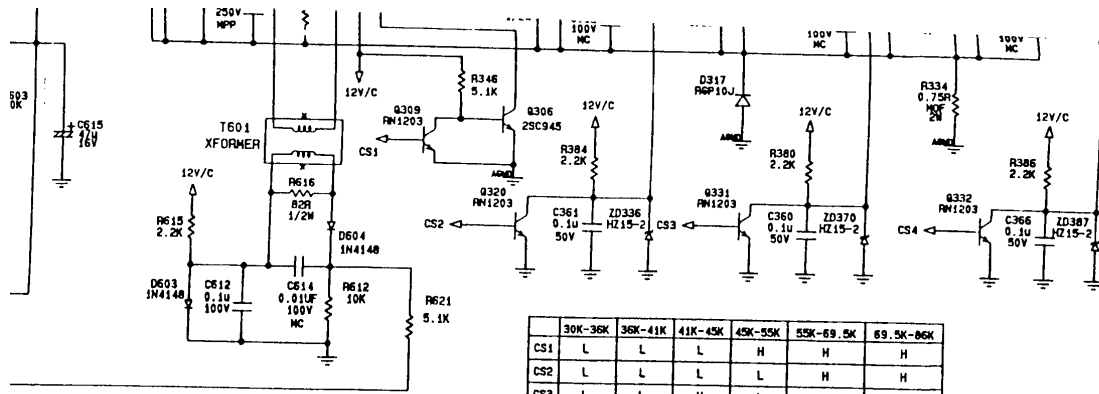

	30K-36K	36K-41K	41K-45K	45K-55K	55K-69.5K	69.5K-86K
CS1	L	L	L	H	H	H
CS2	L	L	L	L	H	H
CS3	L	L	H	L	L	H
CS4	L	H	H	H	H	H

	NOMAL ON	STAND-BY H-OFF/30 W	SUSPEND V-OFF / VSH-OFF / W	MODEL CHANGE	POWER ON
PM61	H1	H1	Lo	H1	H1
PM63	Lo	H1	H1	Lo	
BLK	Lo	H1	H1		
MUTE	Lo	H1	H1		

HOR DC CENTER

SHIFT	6mm TO LEFT	4mm TO L	2mm TO L	6mm TO RIGHT	4mm TO R	2mm TO R
SW301	TURN LEFT	LEFT	LEFT	RIGHT	RIGHT	RIGHT
SW302	TURN RIGHT	CENTER	LEFT	RIGHT	CENTER	LEFT

SIMPLE OF DIRECTION

	LEFT			RIGHT			
mm	6	4	2	0	6	4	2
SW301	←	←	←	↑	→	→	→
SW302	→	↑	←	↑	→	↑	←

VIEWSONIC CORP.		
DRAWING DATE	TOLERANCE	SCALE
11-19-'96	DIM +	ANGLE -
CHANGER	DRAWN BY	DRAWING NO
	OF	ALL IN
MODEL: G800		

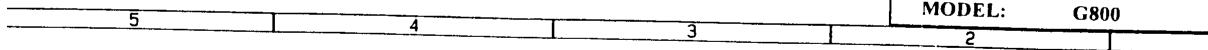

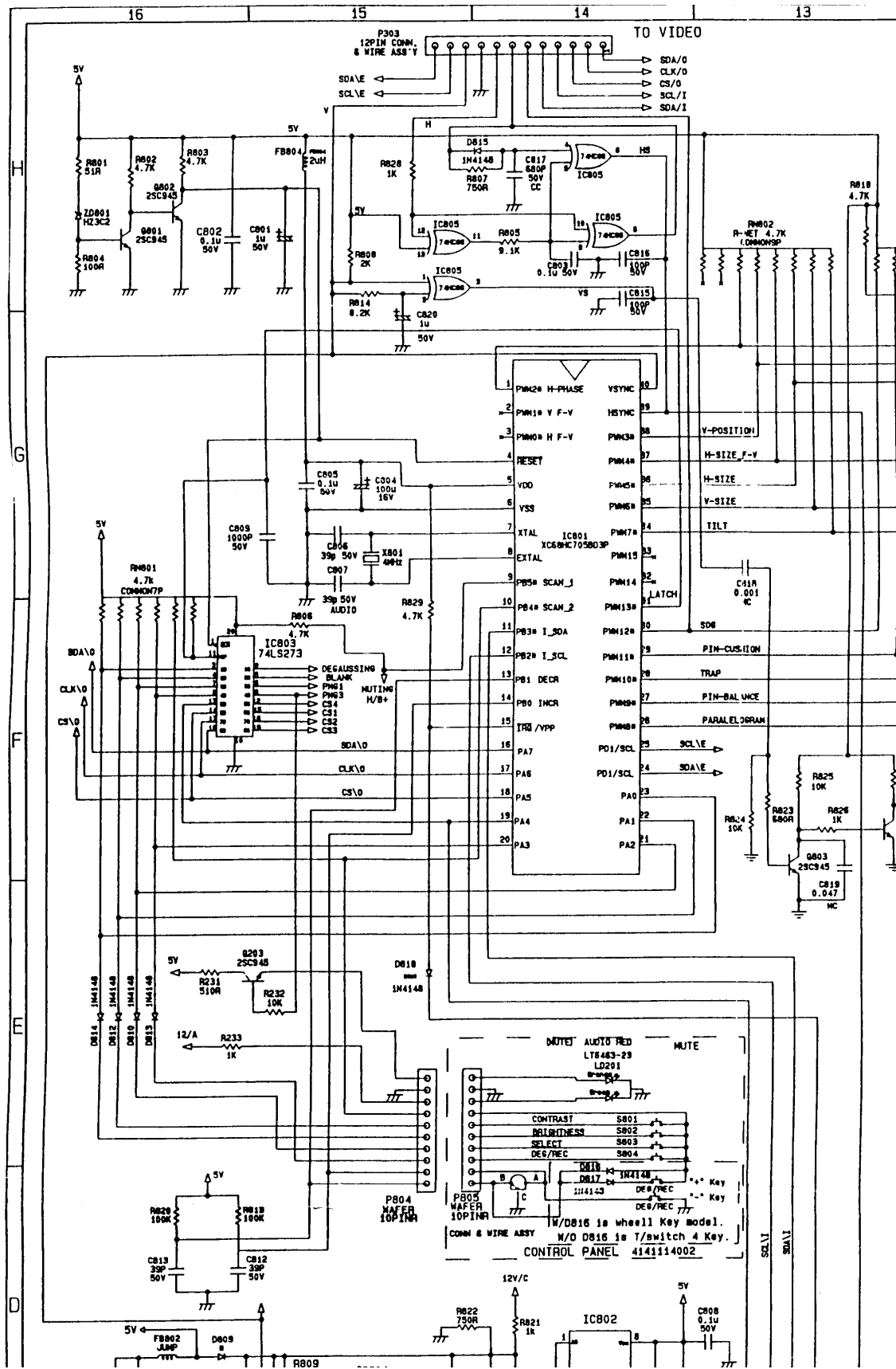

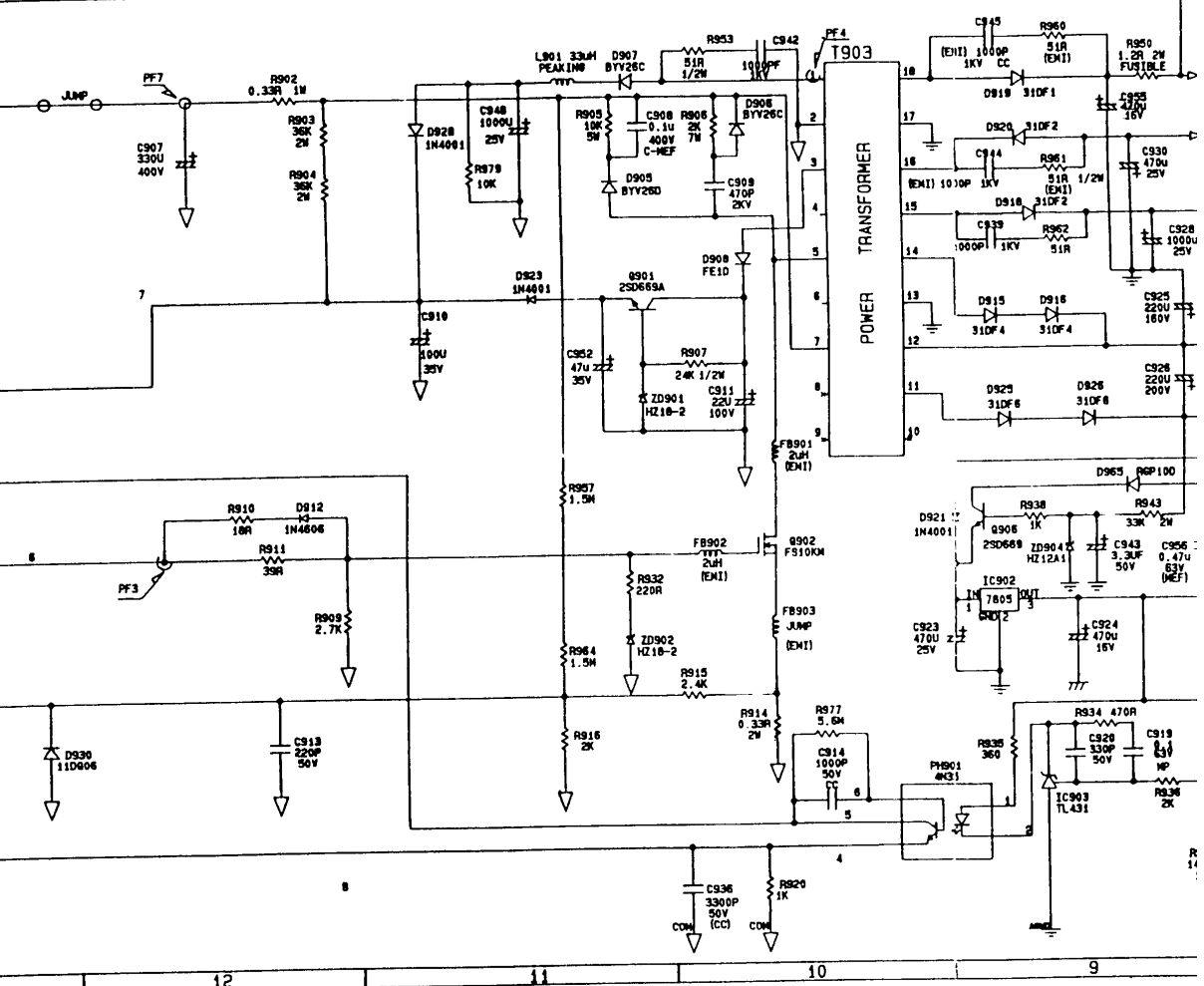
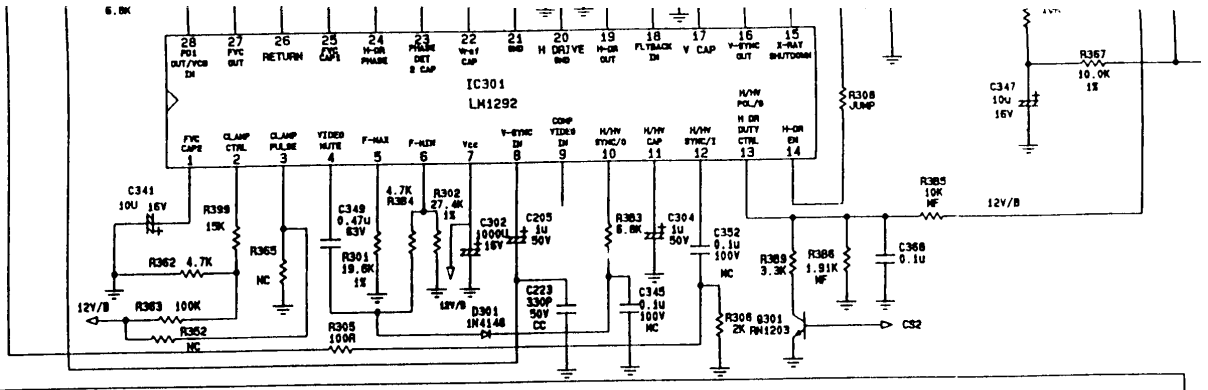

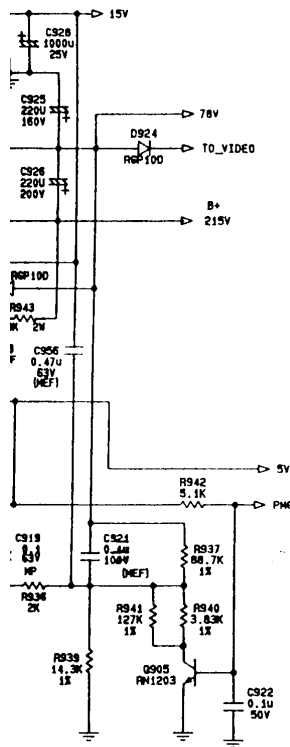
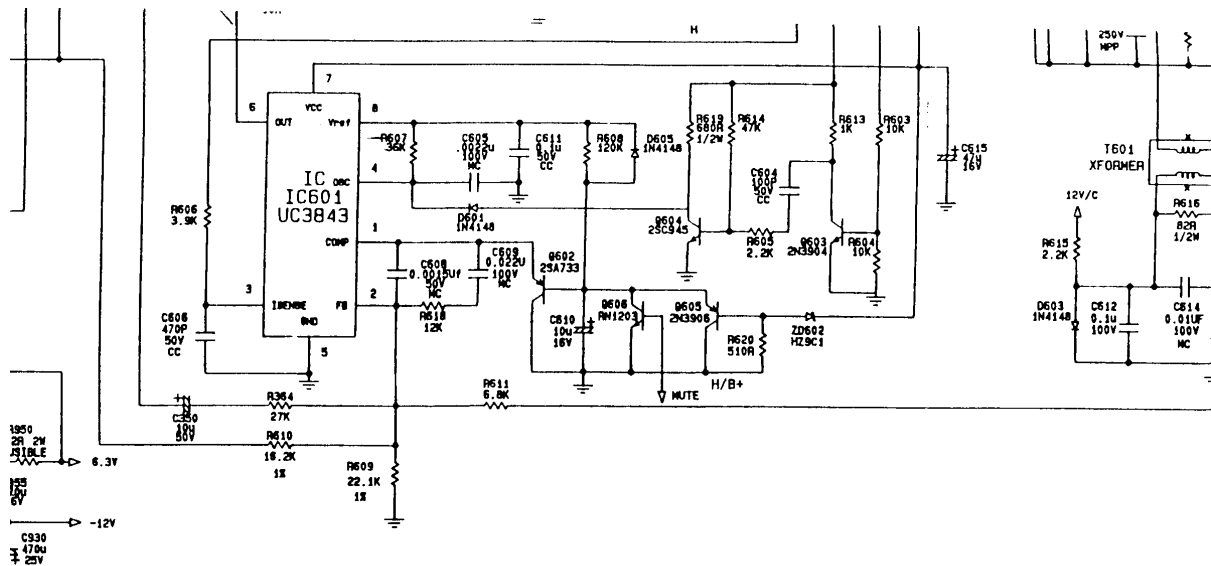

NORMAL	H (5V)
OFF MODE	L (0V)

HOR

SHIFT	6mm TO LEFT	4m
SW301	TURN LEFT	LE
SW302	TURN RIGHT	CE

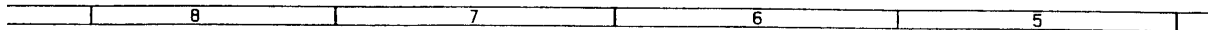

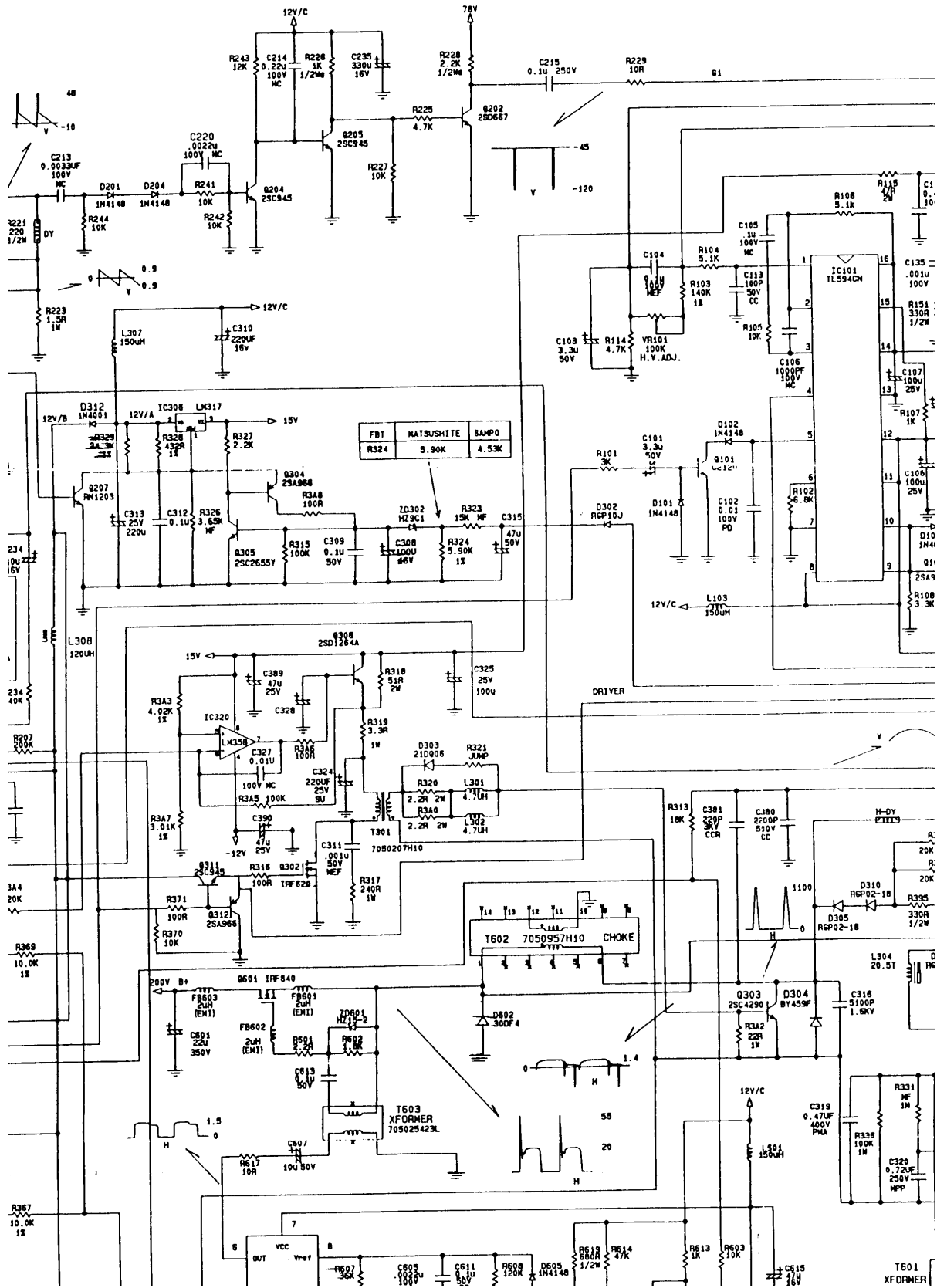

R229
10R

81

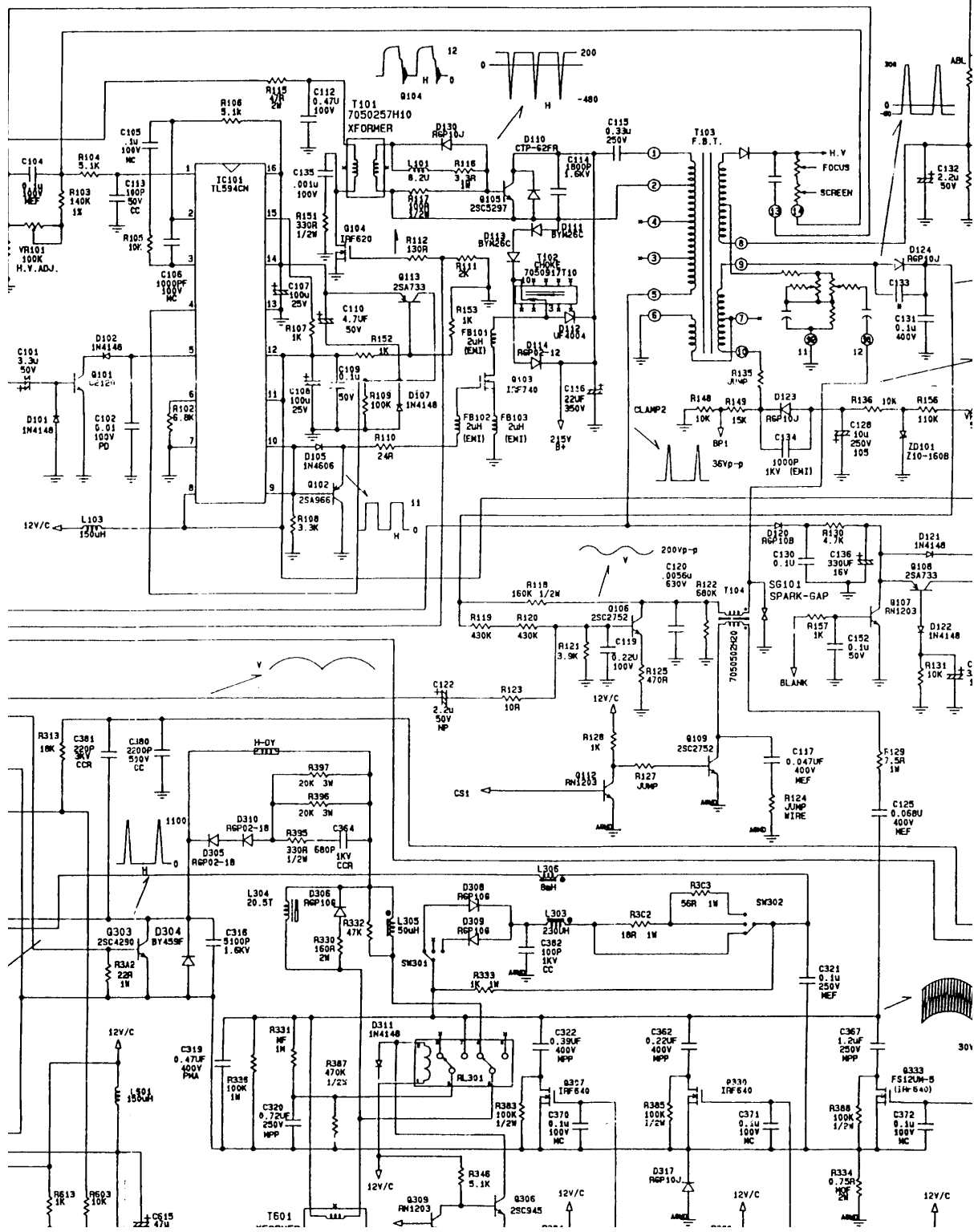

Section 8.

Mechanical Parts

8.1.	Key to Exploded View	8-1
8.2.	Exploded View	8-2

8.1. Key to Exploded View

REF.	PART NO.	DESCRIPTION
1	1QA70K2H22	POWER KNOB
2	8127113008	SCREW PAN(+)/HD CAP M3X8 TAPPI FOR BEZEL & U-BKT
3	1Q010K2H22	BEZEL ASS'Y
4	8081111530	SCREW BIND/HD MACH 1/4"-20X30 FOR BASE & RETAINER
5	C377K21010	WIRE CORE & PLATE 'C' ASS'Y
6	1Q60012H22	#POWER SW HOLDER
7	8418113010	SCREW BIND(+)-TAPPING M3X10 ZI FOR PW SW & PW SW HOLDER X2, PW SW HOLDER & BZL X1
8	4410202006	POWER SWITCH SS-160-7D SPST FOR SW901
9	8026114012	SCREW BIND(+)-TAPPING TRI ANGL FOR CONTROL PCB & BEZEL
10	TH2H220444-V	CONTROL PCB ASS'Y
11	5550451194	COPPER FOIL TAPE W=45 FOR CRT (L=360MM,W=260MM)
12	7010026220	CRT M48KFH380X16 (U) HITACHI CRT
13	4410506330	TCO MYLAR W/CARBON FOR YOKE
14	4410507K21	TCO MYLAR FOR YOKE
15	2004092H20	#CRT FRAME
16	C372H2001Q	WASHER ASS'Y FOR CRT FRAME & BEZEL
17	8418115025	SCREW BID(+)/HD TAPPING M5X25 FOR BEZEL & CRT FRAME
18	8127113006	SCREW PAN(+)/HD CAP TAPPING M3 FOR CRT FRAME & U BKT X2,U-BKT & U-BKT HOLDER X4.
18	8127113006	SCREW PAN(+)/HD CAP TAPPING M3 TOP SHIELD & U-BKT X4,CRT FRAME & TOP SHIELD X2
19	C460670110	TILT RING WIRE ASS'Y 270mm FOR P302
20	C001132H20	CRT BRAID WIRE ASS'Y FOR CRT
21	7020192H20	DEGAUSSING COIL
22	TH2H200144-V	MAIN PCB ASS'Y
23	2005092H20	U-BKT
24	3011100030	NUT ISO HEX M3 ZINC FOR AC LINE FILTER
25	2001092H20	#U-BKT HOLDER
26	36660R1911	RUBBER FOOT FOR CRT & CRT FRAME
27	1Q050K2H20	BASE
28	9005092H22	#DECO PLATE
29	2017094030	GROUND CLAMP FOR I/O CABLE
30	8121114008	SCREW CAP BID(+)-M4X8 TAPPING FOR I/O GND X1
31	C7102H2210	I/O CABLE ASS'Y WDDC 1.8M
32	2007297H10	NECK COVER (F)
33	8026113010	SCREW BIND(+)-TAPPING M3X10 TR FOR VIDEO COVER (F)
34	7067F20122	LINE FILTER IX-0342-P
35	8504113010	SCREW BIND(+)-M3X10 MACH W/DISK FOR AC LINE FILTER
36	TH2H200244-V	NECK PCB ASS'Y
37	2009197H10	NECK SHIELD
38	9004095G21	SPACER FOR VIDEO COVER (B)
39	2008097H10	NECK COVER (B)
40	9010097G10	UL SPONGE 80X70X80
41	5530200102	CORD CRAMPER TH-A
42	2002092H20	#TOP SHIELD
43	2003092H20	#REAR SHIELD
44	1Q020K2H20	BUCKET

REF.	PART NO.	DESCRIPTION
45	8059114045	SCREW BIND(+)-B-2 M4X45 TAPPING FOR BEZEL & BUCKET
46	1006094251	RETAINER
47	1Q040K2H20	TILT BALL
48	8026113015	SCREW STEEL TRI "B" TAPPING BI FOR U-BKT HOLDER & TILT BALL
49	1019094230	FOOT
Other parts list		
REF.	PART NO.	DESCRIPTION
	1414002H22	LENS
	2004197H10	#HEAT SINK FOR NECK COVER (F)
	2011192H22	#POWER SPRING
	463310000N	AC POWER CORD WALL 6FT GRAY U
	5530200102	CORD CRAMPER TH-A FOR NECK COVER (F)
	5541025095	CABLE TIE 2.5X90 FOR CRT FRAME & DEGAUSSING
	5541025160	CABLE TIE-BINDING 2.5X160 FOR FBZ COVER & DY WIRE
	555019S001	CLOTH FILM TAPE #19mm
	555040S002	CLOTH FILM TAPE #40mm FOR TCO MYLAR & WIRE FIX
	9002097G1B	LOGO
	9006092H20	CRT CUSHION
	9012092H22	#MANUAL
	C4595G1110	GND WIRE ASS'Y FOR U TYPE BKT TO VIDEO SHIELD
	C4597H1010	GND WIRE ASS'Y FROM REAR PANNE TO VIDEO SHIELD & TOP SHIELD

8.2. Exploded View

- _____
- _____
- _____
- TAPPIN
- _____
- _____
- PING BI
- BALL
- _____
- _____
- ER (F)
- _____
- _____
- GRY U
- NECK
- _____
- FRAME
- _____
- FOR
- _____
- _____
- R TCC
- _____
- _____
- E BKT
- _____
- ANNEI
- _____

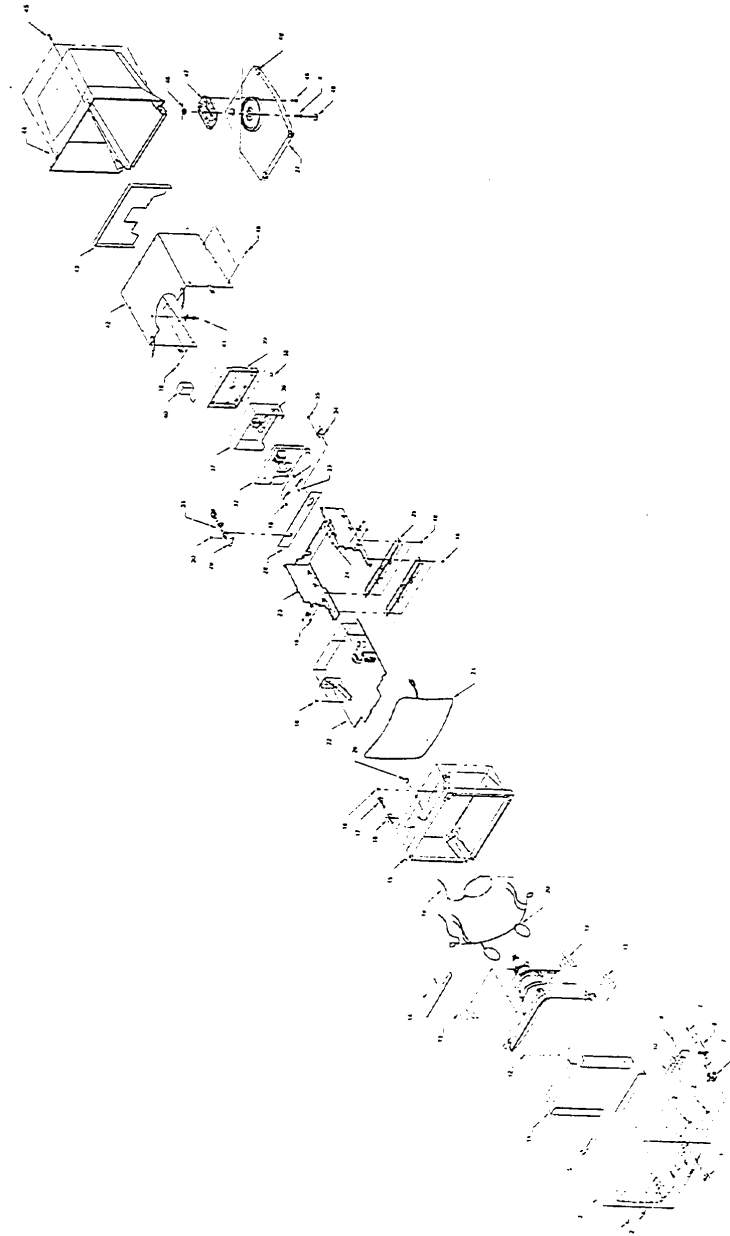

Figure 8-1 Exploded View

Section 9.

PCB Component List

9.1.	Explanation of Parts Listing.	9-1
9.2.	Main Board	9-1
9.3.	Neck Board	9-6
9.4.	Control Board	9-10
9.5.	Different List	9-10

9.1. Explanation of Parts Listing

This section contains a complete listing of the components used on the printed circuit boards contained in the system. For a listing of the mechanical parts, please refer to Section 8., Mechanical Parts.

The list of parts in this section is separated by PCB, and the order of the listing is based on the location reference (REF.) printed on the circuit board and shown in the schematics. Components without a reference location are listed at the beginning of each table in order of the part number, and the location reference of the part with which they are connected is given in the description.

For example:

	2003097301	HEAT SINK FOR Q1
--	------------	------------------

shows Part No. 2003097301, which is connected or related to the components with a location reference of Q1.

Shaded items indicate components that are critical for safety or are of proprietary design and must be replaced with parts of the exact same specification or ordered directly from the manufacturer.

For example:

Q1	4101515070	TRS. MOSFET 2SK1507 TO-220
----	------------	----------------------------

Indicates that the TRS. MOSFET, Part No. 4101515070 located at reference Q1, should only be replaced with the exact same part ordered from the manufacturer.

9.2. Main Board

REF.	PART NO.	DESCRIPTION
	TH2H200144	MAIN PCB ASSY
	1003090000	NYLON BUSHING FOR Q103, 601 (IRF740, IRF840, STP10NA40)
	2000000011	CLIP WIRE FOR MAIN WIRE
	2003294030	HEAT SINK VIDEO FOR IC306
	2004097H10	HEAT SINK A FOR FBT COVER
	2004191630	HEAT SINK HOLDER FOR Q902 (TRS.FS10KM-12)
	2005092H20	#U-BKT
	2005197H10	#FBT COVER FOR FBT
	2009197H10	#NECK SHIELD
	2011092H20	#HEAT SINK FOR Q902
	2017097H10	HEAT SINK FOR IC201
	2046294000	HEAT SINK F FOR IC902
	2046294000	HEAT SINK F FOR Q308
	3011100030	NUT ISO HEX M3 ZINC FOR AC LINE FILTER
	3011100030	NUT ISO HEX M3 ZINC FOR IC306
	3340230165	BEAD PIN 16.5X2.3c FOR R901 X2
	36823TA103	WIRE HOLDER TA10-35 FOR MAIN PCB & BKT
	4141119601	#P.C.B. MAIN
	41A2H00V01	FIRMWARE VERSION:V010 CHECK SU
	4692300001	CLIP-FUSE 5MM FOR F301
	5318201311	WIRE 1015 #18 BLK 120-5-5 FOR C-C', D-D'
	5322200601	WIRE UL1007 #22 BLK 50-5-5 FOR F-F

REF.	PART NO.	DESCRIPTION
	5322201034	WIRE UL1617 #22 BLK 90-TERMINA FOR E-E'
	5324113200	WIRE UL1007 #24 BRN 310-K-K FOR A-A'
	5324133500	WIRE UL1007 #24 ORG 340-K-K FOR B-B'
	5520100004	INSULATOR SI-RUBBER TO-220 (W/ FOR Q103, 601 (IRF740, IRF840, STP10NA40)
	5520100005	INSULATOR SI-RUBBER TO-3P FOR Q303
	5541025095	CABLE TIE 2.5X90 FOR P302 & 301 X4, G2 WIRE X4
	555019S001	CLOTH FILM TAPE #19mm
	5560080003	CORE-FE 2643665802 FOR FOCUS, G2 WIRE
	8026113006	SCREW B/H0 M3X6 TAPPING 'B' FOR PCB & Q902 HEAT SINK
	8026113008	SCREW B/H0 M3X8 TAPPING 'B' FOR H/S & FBT COVER X2,FBT COVER ASS'Y X2
	8026113008	SCREW B/H0 M3X8 TAPPING 'B' FOR PCB & FBT COVER X2
	8026113010	SCREW BIND(+) TAPPING M3X10 TR FOR IC201
	8127113006	SCREW PANI(+)/HD CAP TAPPING M3X5 FOR GND WIRE FIX
	8127113006	SCREW PANI(+)/HD CAP TAPPING M3X6 FOR U-BKT & MAIN PCB X7,U-BKT GND X1,GND WIRE FIX
	8128142608	SCREW B/H W/CAP 'B' 2.6X8 TITE FOR CLIP WIRE & HEAT SINK
	8504113008	SCREW BIND(+) M3X8 MACH W/DISK FOR IC902
	8504113008	SCREW BIND(+) M3X8 MACH W/DISK FOR C308
	8504113010	SCREW BIND(+) M3X10 MACH W/DISK FOR AC LINE FILTER
	8504113010	SCREW BIND(+) M3X10 MACH W/DISK FOR D110,304, Q103,105,303,601
	8504113010	SCREW BIND(+) M3X10 MACH W/DISK FOR IC306
	8504113016	SCREW BID(+) MACH W/D ZINC M3X16 FOR FC902 (TRS.FS10KM-12)
	9011294230	LABEL 28KV
	C459455010	GND WIRE ASSY FOR VIDEO SHIELD TO DEF HEAT SINK
	C4597K1110	GND WIRE ASSY 200mm FOR MAIN PCB TO U-BRACKET
	C488100025	CONN. 10P & WIRE ASSY 350mm W P301 & P3
	C488120040	CONN. 12P & WIRE ASSY 400mm P303 & P2
BD901	4130400080	DIODE BRIDGE 4A/800V P-5.0MM
BP1	C4607F4120	WIRE ASSY 300MM
C101	5156339T50	CAP-EC6 3.3UFM 50V -RT-
C102	5092103615	CAP-PP 01UFG 100V P-10mm -SF-
C103	5156339T50	CAP-EC6 3.3UFM 50V -RT-
C104	5074104101	CAP-MEF 0.1UFK 100V -SF-
C105	5116104111	CAP-MC 0.1UFK 100V -RT-
C106	5116102111	CAP-MC 0.001UFK 100V -RT-
C107	5156101T25	CAP-EC6 100UFM 25V -RT-
C108	5156101T25	CAP-EC6 100UFM 25V -RT-
C109	5134104452	CAP-SCF 0.1UFZ 50V -RT-
C110	5156479T50	CAP-EC6 4.7UFM 50V -RT-
C112	5113474111	CAP-MC 0.47JFK 100V -SF-
C113	5128101552	CAP-CSSL 100PFJ 50V -RT-
C114	5192182573	CAP-MPP 1800PFJ 1.6KV P-15mm

PCB Component List

REF.	PART NO.	DESCRIPTION
C115	5190334583	CAP-MPP 0.33UFJ 250V -SF-
C116	5156220509	CAP-EC6 22UFM 350V -SF-
C117	5074473104	CAP-MEF 0.047UFK 400V -SF-
C119	5113224111	CAP-MC 0.22UFK 100V -SF-
C120	5092562562	CAP-PP 0.0056UFJ 630V P:10mm
C121	5156331T16	CAP-EC6 330UFM 16V -RT-
C122	5162229T50	CAP-NPEC 2.2UFM 50V -RT-
C125	5074683104	CAP-MEF 0.068UFK 400V -SF-
C128	515X100503	CAP-ECX 10UFM 250V -SF-
C130	5116104111	CAP-MC 0.1UFK 100V -RT-
C131	5074104104	CAP-MEF 0.1UFK 400V P:15MM -SF
C132	5156229T50	CAP-EC6 2.2UFM 50V -RT-
C134	510H102133	CAP-CCR 1000PFK 1KV P:5.0mm
C135	5116102111	CAP-MC 0.001UFK 100V -RT-
C136	5156331T16	CAP-EC6 330UFM 16V -RT-
C150	5134104452	CAP-SCF 0.1UFZ 50V -RT-
C151	5134104452	CAP-SCF 0.1UFZ 50V -RT-
C152	5134104452	CAP-SCF 0.1UFZ 50V -RT-
C155	5134104452	CAP-SCF 0.1UFZ 50V -RT-
C201	5134104452	CAP-SCF 0.1UFZ 50V -RT-
C202	5156100T16	CAP-EC6 10UFM 16V -RT-
C203	5156101T16	CAP-EC6 10UFM 16V -RT-
C204	5156479T50	CAP-EC6 4.7UFM 50V -RT-
C205	5156109T50	CAP-EC6 1UFM 50V -RT-
C206	5156100T16	CAP-EC6 10UFM 16V -RT-
C207	5156100T16	CAP-EC6 10UFM 16V -RT-
C208	5156479T50	CAP-EC6 4.7UFM 50V -RT-
C209	515X471S25	CAP-ECX 470UFM 25V -SF-
C210	515X221S35	CAP-ECX 220UFM 35V -SF-
C211	515X471S25	CAP-ECX 470UFM 25V -SF-
C212	5113224111	CAP-MC 0.22UFK 100V -SF-
C213	5116332111	CAP-MC 0.0033UFK 100V -RT-
C214	5113224111	CAP-MC 0.22UFK 100V -SF-
C215	5074104102	CAP-MEF 0.1UFK 250V -SF-
C216	515X471S16	CAP-ECX 470UFM 16V -SF-
C217	515X101T16	CAP-ECX 100UFM 16V -RT-
C218	5074474505	CAP-MP 0.47UFJ 50V P:5.0MM
C220	5116222111	CAP-MC 0.0022UFK 100V -RT-
C221	5134104452	CAP-SCF 0.1UFZ 50V -RT-
C222	5128821552	CAP-CCSL 820PFJ 50V -RT-
C223	5126331552	CAP-CCSL 330PFJ 50V -RT-
C224	5156109T50	CAP-EC6 1UFM 50V -RT-
C225	5116333111	CAP-MC 0.033UFK 100V -RT-
C226	5156229T50	CAP-EC6 2.2UFM 50V -RT-
C228	5156229T50	CAP-EC6 2.2UFM 50V -RT-
C230	5101102152	CAP-CCB 1000PFK 50V -RT-
C231	5116122111	CAP-MC 0.0012UFK 100V -RT-
C232	5116104111	CAP-MC 0.1UFK 100V -RT-
C234	5156100T16	CAP-EC6 10UFM 16V -RT-
C235	5156331T16	CAP-EC6 330UFM 16V -RT-
C301	5156471T16	CAP-EC6 470UFM 16V -RT-
C302	5156102S16	CAP-EC6 1000UFM 16V -SF-
C303	5134104452	CAP-SCF 0.1UFZ 50V -RT-
C304	5156109T50	CAP-EC6 1UFM 50V -RT-
C307	5116223111	CAP-MC 0.022UFK 100V -RT-
C308	5156101T16	CAP-EC6 100UFM 16V -RT-
C309	5134104452	CAP-SCF 0.1UFZ 50V -RT-
C310	5156221T16	CAP-EC6 220UFM 16V -RT-
C311	5075102505	CAP-MEF 1000PFJ 50V CF
C312	5134104452	CAP-SCF 0.1UFZ 50V -RT-

REF.	PART NO.	DESCRIPTION
C313	5156221T25	CAP-EC6 220UFM 25V -RT-
C314	5156100T16	CAP-EC6 10UFM 16V -RT-
C315	5156470T50	CAP-EC6 47UFM 50V -RT-
C316	5195512573	CAP-PMHA 5100PFJ 1600V P:22.5m
C319	5195474543	CAP-PMA 0.47UFJ 400V -SF-
C320	5190724583	CAP-MPP 0.72UFJ 250V -SF-
C321	5074104102	CAP-MEF 0.1UFK 250V -SF-
C322	5190394543	CAP-MPP 0.39UFJ 400V P:22.5mm
C324	515X221T25	CAP-ECX 220UFM 25V -RT-
C325	5156101T25	CAP-EC6 100UFM 25V -RT-
C327	5116103111	CAP-MC 0.01UFK 100V -RT-
C332	5156100T16	CAP-EC6 10UFM 16V -RT-
C333	5156100T16	CAP-EC6 10UFM 16V -RT-
C334	5134104452	CAP-SCF 0.1UFZ 50V -RT-
C336	5134104452	CAP-SCF 0.1UFZ 50V -RT-
C338	5156100T16	CAP-EC6 10UFM 16V -RT-
C339	5156100T16	CAP-EC6 10UFM 16V -RT-
C340	5156109T50	CAP-EC6 1UFM 50V -RT-
C341	5156100T16	CAP-EC6 10UFM 16V -RT-
C342	5116222111	CAP-MC 0.0022UFK 100V -RT-
C343	5116104111	CAP-MC 0.1UFK 100V -RT-
C344	5116472111	CAP-MC 0.0047UFK 100V -RT-
C345	5116104111	CAP-MC 0.1UFK 100V -RT-
C346	5074474505	CAP-MP 0.47UFJ 50V P:5.0MM
C347	5156100T16	CAP-EC6 10UFM 16V -RT-
C348	5156100T16	CAP-EC6 10UFM 16V -RT-
C349	5075474563	CAP-MEF 0.47UFJ 63V P:5.0mm -R
C350	5156100T50	CAP-EC6 10UFM 50V -RT-
C351	5121560552	CAP-COCH 56PFJ 50V -RT-
C352	5116104111	CAP-MC 0.1UFK 100V -RT-
C353	5116104111	CAP-MC 0.1UFK 100V -RT-
C355	5134104452	CAP-SCF 0.1UFZ 50V -RT-
C360	5134104452	CAP-SCF 0.1UFZ 50V -RT-
C361	5134104452	CAP-SCF 0.1UFZ 50V -RT-
C362	5190224543	CAP-MPP 0.22UFJ 400V P:22.5MM
C363	5116104111	CAP-MC 0.1UFK 100V -RT-
C364	510H681133	CAP-CCR 680PFK 1KV P:5mm -SF-
C365	5156100T16	CAP-EC6 10UFM 16V -RT-
C366	5134104452	CAP-SCF 0.1UFZ 50V -RT-
C367	5190125583	CAP-MPP 1.2UFJ 250V -SF-
C368	5134104452	CAP-SCF 0.1UFZ 50V -RT-
C369	5134104452	CAP-SCF 0.1UFZ 50V -RT-
C370	5116104111	CAP-MC 0.1UFK 100V -RT-
C371	5116104111	CAP-MC 0.1UFK 100V -RT-
C372	5116104111	CAP-MC 0.1UFK 100V -RT-
C380	5101222142	CAP-CCB 2200PFK 500V -RT-
C381	510H221193	CAP-CCR 220PFK 3KV P:7.5mm -SF
C382	5101101132	CAP-CCB 100PFK 1KV -RT-
C388	5156100T16	CAP-EC6 10UFM 16V -RT-
C389	5156470T25	CAP-EC6 47UFM 25V -RT-
C390	5156470T25	CAP-EC6 47UFM 25V -RT-
C391	5116104111	CAP-MC 0.1UFK 100V -RT-
C601	5156220509	CAP-EC6 22UFM 350V -SF-
C604	5128101552	CAP-CCSL 100PFJ 50V -RT-
C605	5116222111	CAP-MC 0.0022UFK 100V -RT-
C606	5128471552	CAP-CCSL 470PFJ 50V -RT-
C607	5156100T50	CAP-EC6 10UFM 50V -RT-
C608	5128561552	CAP-CCSL 560PFJ 50V -RT-
C609	5116223111	CAP-MC 0.022UFK 100V -RT-
C610	5156100T16	CAP-EC6 10UFM 16V -RT-

G800 Service Manual

REF.	PART NO.	DESCRIPTION
C611	5134104452	CAP-SCF 0.1UFZ 50V -RT-
C612	5116104111	CAP-MC 0.1UFK 100V -RT-
C613	5134104452	CAP-SCF 0.1UFZ 50V -RT-
C614	5116103111	CAP-MC 0.01UFK 100V -RT-
C615	5156470T16	CAP-EC6 47UFM 16V -RT-
C801	5156109T50	CAP-EC6 1UFM 50V -RT-
C802	5134104452	CAP-SCF 0.1UFZ 50V -RT-
C803	5134104452	CAP-SCF 0.1UFZ 50V -RT-
C804	5156101T16	CAP-EC6 100UFM 16V -RT-
C805	5134104452	CAP-SCF 0.1UFZ 50V -RT-
C806	5128390552	CAP-CSSL 39PFJ 50V -RT-
C807	5128390552	CAP-CSSL 39PFJ 50V -RT-
C808	5134104452	CAP-SCF 0.1UFZ 50V -RT-
C809	5101102152	CAP-CCB 1000PFK 50V -RT-
C810	5128221552	CAP-CSSL 220PFJ 50V -RT-
C811	5128221552	CAP-CSSL 220PFJ 50V -RT-
C812	5128390552	CAP-CSSL 39PFJ 50V -RT-
C813	5128390552	CAP-CSSL 39PFJ 50V -RT-
C814	5134104452	CAP-SCF 0.1UFZ 50V -RT-
C815	5128101552	CAP-CSSL 100PFJ 50V -RT-
C816	5128101552	CAP-CSSL 100PFJ 50V -RT-
C817	5128681552	CAP-CSSL 680PFJ 50V -RT-
C818	5116102111	CAP-MC 0.001UFK 100V -RT-
C819	5116473111	CAP-MC 0.047UFK 100V -RT-
C820	5156109T50	CAP-EC6 1UFM 50V -RT-
C902	5065224428	CAP-MPR 0.22UFM 275V -SF-
C903	5061472440	CAP-CCS 4700PFM 400V -SF-
C904	5061472440	CAP-CCS 4700PFM 400V -SF-
C905	5061472440	CAP-CCS 4700PFM 400V -SF-
C906	5061472440	CAP-CCS 4700PFM 400V -SF-
C907	515L331S04	CAP-ECL 330UFM 400V -SF-
C908	5074104104	CAP-MEF 0.1UFK 400V P:15MM -SF
C909	510H4711C3	CAP-CCR 470PFK 2KV P:7.5mm -SF
C910	5156101T35	CAP-EC6 100UFM 35V -RT-
C911	5156220T01	CAP-EC6 22UFM 100V -RT-
C912	5092103615	CAP-PP 01UFG 100V P:10mm -SF-
C913	5101221152	CAP-CCB 220PFK 50V -RT-
C914	5101102152	CAP-CCB 1000PFK 50V -RT-
C915	5156109T50	CAP-EC6 1UFM 50V -RT-
C917	5156331T16	CAP-EC6 330UFM 16V -RT-
C918	5134104452	CAP-SCF 0.1UFZ 50V -RT-
C919	5074104163	CAP-MEF 0.1UFK 63V -SF-
C920	5128331552	CAP-CSSL 330PFJ 50V -RT-
C921	5074104101	CAP-MEF 0.1UFK 100V -SF-
C922	5134104452	CAP-SCF 0.1UFZ 50V -RT-
C923	5156471S25	CAP-EC6 470UFM 25V -SF-
C924	5156471T16	CAP-EC6 470UFM 16V -RT-
C925	5156221S02	CAP-EC6 220UFM 160V -SF-
C926	5156221S07	CAP-EC6 220UFM 200V -SF-
C928	5156102S25	CAP-EC6 1000UFM 25V -SF-
C930	5156471T25	CAP-EC6 470UFM 25V -RT-
C931	5134104452	CAP-SCF 0.1UFZ 50V -RT-
C932	5065105425	CAP-MPR 1UFM 250V -SF-
C935	5101332152	CAP-CCB 3300PFK 50V -RT-
C939	510H102133	CAP-CCR 1000PFK 1KV P:5.0mm
C942	5101102132	CAP-CCB 1000PFK 1KV -RT-
C943	5156339T50	CAP-EC6 3.3UFM 50V -RT-
C944	510H102133	CAP-CCR 1000PFK 1KV P:5.0mm
C945	5101102132	CAP-CCB 1000PFK 1KV -RT-
C948	5156102S25	CAP-EC6 1000UFM 25V -SF-

REF.	PART NO.	DESCRIPTION
C949	5061472440	CAP-CCS 4700PFM 400V -SF-
C950	5061472440	CAP-CCS 4700PFM 400V -SF-
C952	5156470T35	CAP-EC6 47UFM 35V -RT-
C955	515X471S16	CAP-ECX 470UFM 16V -SF-
C956	5075474563	CAP-MEF 0.47UFJ 63V P:5.0mm -R
D101	4120141480	DIODE 1N4148 (SI) -AT-
D102	4120141480	DIODE 1N4148 (SI) -AT-
D105	4120146060	DIODE 1N4606 (SI) -AT-
D107	4120141480	DIODE 1N4148 (SI) -AT-
D110	41305002F0	DIODE FMP-G2FS TO-220AB 1500V
D111	413020426C	DIODE 2.3A/600V BYM26C -AT-
D112	4130104004	DIODE UF4004 400V/1A -AT-
D113	413020426C	DIODE 2.3A/600V BYM26C -AT-
D114	4130010212	DIODE RGP02-12E 1200V/0.5A -AT
D120	413010010B	DIODE RGP10B-5391 -AT-
D121	4120141480	DIODE 1N4148 (SI) -AT-
D122	4120141480	DIODE 1N4148 (SI) -AT-
D123	413010010J	DIODE RGP10J-5390 1A 600V -AT-
D124	413010010J	DIODE RGP10J-5390 1A 600V -AT-
D125	4120141480	DIODE 1N4148 (SI) -AT-
D130	413010010J	DIODE RGP10J-5390 1A 600V -AT-
D201	4120141480	DIODE 1N4148 (SI) -AT-
D202	4120104001	DIODE 1N4001 -AT-
D204	4120141480	DIODE 1N4148 (SI) -AT-
D301	4120141480	DIODE 1N4148 (SI) -AT-
D302	413010010J	DIODE RGP10J-5390 1A 600V -AT-
D303	4130172106	DIODE 21DQ06 1.7A/60V -AT-
D304	4131014590	DIODE BY459F-1500 SOD-100
D305	4130100218	DIODE RGP02-18E-5300 -AT-
D306	413010010G	DIODE RGP10G-5390 -AT-
D307	4120141480	DIODE 1N4148 (SI) -AT-
D308	413010010G	DIODE RGP10G-5390 -AT-
D309	413010010G	DIODE RGP10G-5390 -AT-
D310	4130100218	DIODE RGP02-18E-5300 -AT-
D311	4120141480	DIODE 1N4148 (SI) -AT-
D312	4120104001	DIODE 1N4001 -AT-
D313	4120141480	DIODE 1N4148 (SI) -AT-
D314	4120141480	DIODE 1N4148 (SI) -AT-
D317	413010010J	DIODE RGP10J-5390 1A 600V -AT-
D601	4120141480	DIODE 1N4148 (SI) -AT-
D602	41303030F4	DIODE 30DF4
D603	4120141480	DIODE 1N4148 (SI) -AT-
D604	4120141480	DIODE 1N4148 (SI) -AT-
D605	4120141480	DIODE 1N4148 (SI) -AT-
D605	4120141480	DIODE 1N4148 (SI) -AT-
D806	4120141480	DIODE 1N4148 (SI) -AT-
D807	4120141480	DIODE 1N4148 (SI) -AT-
D808	4120141480	DIODE 1N4148 (SI) -AT-
D810	4120141480	DIODE 1N4148 (SI) -AT-
D812	4120141480	DIODE 1N4148 (SI) -AT-
D813	4120141480	DIODE 1N4148 (SI) -AT-
D814	4120141480	DIODE 1N4148 (SI) -AT-
D815	4120141480	DIODE 1N4148 (SI) -AT-
D818	4120141480	DIODE 1N4148 (SI) -AT-
D905	413010425D	DIODE 1A/800V BYV25D
D906	413010426C	DIODE BYV26C KINK FORMING -AT-
D907	413010426C	DIODE BYV26C KINK FORMING -AT-
D908	413010001D	DIODE FE1D-5390
D909	4120141480	DIODE 1N4148 (SI) -AT-
D910	4120141480	DIODE 1N4148 (SI) -AT-

PCB Component List

REF.	PART NO.	DESCRIPTION
D911	4120141480	DIODE 1N4148 (SI) -AT-
D912	4120148060	DIODE 1N4606 (SI) -AT-
D913	4120141480	DIODE 1N4148 (SI) -AT-
D914	4120141480	DIODE 1N4148 (SI) -AT-
D915	41303031F4	DIODE 3A/400V 35NS 31DF4 -AT-
D916	41303031F4	DIODE 3A/400V 35NS 31DF4 -AT-
D918	41303031F2	DIODE 3A/200V 31DF2
D919	4130304311	DIODE 31DF1 -AT-
D920	41303031F2	DIODE 3A/200V 31DF2
D921	4120104001	DIODE 1N4001 -AT-
D922	4120141480	DIODE 1N4148 (SI) -AT-
D923	4120104001	DIODE 1N4001 -AT-
D924	413010010D	DIODE RGP10D-5302 -AT- 1A
D925	41303031F6	DIODE 31DF6
D926	41303031F6	DIODE 31DF6
D928	4120104001	DIODE 1N4001 -AT-
D930	41301011Q6	DIODE 11DQ06 -AT-
D965	413010010D	DIODE RGP10D-5302 -AT- 1A
DY	4490400207	CONN. 4P WAFER ROUND PIN
F901	5268400052	FUSE 4A/250VAC
FB101	4322209046	FERRITE BEAD 2UH -AT-
FB102	4322209046	FERRITE BEAD 2UH -AT-
FB103	4322209046	FERRITE BEAD 2UH -AT-
FB601	4322209046	FERRITE BEAD 2UH -AT-
FB602	4322209046	FERRITE BEAD 2UH -AT-
FB603	4322209046	FERRITE BEAD 2UH -AT-
FB801	4322209046	FERRITE BEAD 2UH -AT-
FB803	4322209046	FERRITE BEAD 2UH -AT-
FB804	4322209046	FERRITE BEAD 2UH -AT-
FB901	4322209046	FERRITE BEAD 2UH -AT-
FB902	4322209046	FERRITE BEAD 2UH -AT-
IC101	4159594000	IC TL594CN 16PIN
IC201	4159817200	IC TDA8172 7PIN
IC301	4159129200	IC LM1292 28PIN
IC302	4159129500	IC LM1295 24PIN
IC306	4159317001	IC LM317T W/MOUNTING KIT TO-22
IC320	4159358000	IC LMT358N 8PIN
IC601	4159364300	IC UC3843A 8PIN
IC801	4159667052	#IC XC68HC705BD5P VER1.0 2H20
IC802	415924L160	IC 24LC16 8PIN DIP
IC803	4152742730	IC 74LS273 20PIN
IC804	4159242100	IC 24LC21 8PIN
IC805	4155074860	IC 74HC86 14PIN
IC901	4159384200	IC UC3842A 8PIN
IC902	4159780501	IC 7805 REGULATOR 3PIN
IC903	415843100A	IC TL431 REGULATOR TO-92 -RT-
L101	4321829006	COIL PEAKING 8.2UH -AT-
L103	4321151006	COIL PEAKING 150UH -AT-
L301	4321479006	COIL PEAKING 4.7UH -AT-
L302	4321479006	COIL PEAKING 4.7UH -AT-
L303	4323231003	CHOKE COIL 230uH
L304	708S202H22	COIL LINEARITY
L305	4323500003	COIL CHOKE 50UH -SF-
L306	4323809503	#COIL CHOKE 8mH
L307	4321151006	COIL PEAKING 150UH -AT-
L308	4321121006	COIL PEAKING 120UH -AT-
L601	432A151006	COIL PEAKING 150UH SMALL -AT-
L901	4321330006	COIL PEAKING 33UH -AT-
P302	4490200130	CONN. 2P WAFER 2.5MM
P902	4490401826	CONN. 4P P/A 171826-04

REF.	PART NO.	DESCRIPTION
P804	4491000260	CONN. 10P WAFER TYPE:1-173981-
P901	7067F20122	LINE FILTER IX-0342-P
P902	4490300190	CONN. 3.96 3P W/O PIN 2 -SF-
P903	4490200207	CONN. 2P WAFER ROUND PIN 10MM
PH901	4159435002	POTO COUPLER X'STER 4N35 W=10
PTCR	7021141400	PTCR DGC 2R14M
Q101	411022120Y	TRS. 2SC2120Y TO-92 -RT-
Q102	4110009560	TRS. 2SA966 TPE6 TO-92M -RT-
Q103	4105907400	TRS. IRF740
Q104	4105906200	TRS. MOSFET IRF620 TO-220
Q105	4100252970	TRS. 2SC5297 TO-3P
Q106	4100227520	TRS. 2SC2752-K TO-125
Q107	4116612030	TRS. RN1203 -RT-
Q108	4110007330	TRS. 2SA733 TO-92M -RT-
Q109	4100227520	TRS. 2SC2752-K TO-125
Q110	4110007330	TRS. 2SA733 TO-92M -RT-
Q111	4112409200	TRS. KSP92 TO-92
Q112	4116612030	TRS. RN1203 -RT-
Q113	4110007330	TRS. 2SA733 TO-92M -RT-
Q202	411030667C	TRS. 2SD667C TO-92M -RT-
Q203	411020945P	TRS. 2SC945P TO-92 -RT-
Q204	411020945P	TRS. 2SC945P TO-92 -RT-
Q205	411020945P	TRS. 2SC945P TO-92 -RT-
Q206	411020945P	TRS. 2SC945P TO-92 -RT-
Q207	4116612030	TRS. RN1203 -RT-
Q301	4116612030	TRS. RN1203 -RT-
Q302	4105906200	TRS. MOSFET IRF620 TO-220
Q303	410024290A	TRS. 2SC4290A TO-3PL
Q304	4110008660	TRS. 2SA966 TPE6 TO-92M -RT-
Q305	411022655Y	TRS. 2SC2655-Y TO-92M -RT-
Q306	411020945P	TRS. 2SC945P TO-92 -RT-
Q307	4105906400	TRS. IRF640 TO-220
Q308	410031264A	TRS. 2SD1264A
Q309	4116612030	TRS. RN1203 -RT-
Q311	411020945P	TRS. 2SC945P TO-92 -RT-
Q312	4110009560	TRS. 2SA966 TPE6 TO-92M -RT-
Q320	4116612030	TRS. RN1203 -RT-
Q330	4105906400	TRS. IRF640 TO-220
Q331	4116612030	TRS. RN1203 -RT-
Q332	4116612030	TRS. RN1203 -RT-
Q333	41035012U0	TRS. FS12UM-5 TO-220AB 250V/1
Q340	410030669A	TRS. 2SD669A TO-126
Q341	411010647C	TRS. 2SB647C TO-92M -RT-
Q601	4100808400	TRS. YTAf840 TO-220F
Q602	4110007330	TRS. 2SA733 TO-92M -RT-
Q603	4111139040	TRS. 2N3904 TO-92 -RT-
Q604	411020945P	TRS. 2SC945P TO-92 -RT-
Q605	4111139050	TRS. 2N3906 TO-92 -RT-
Q606	4116612030	TRS. RN1203 -RT-
Q801	411020945P	TRS. 2SC945P TO-92 -RT-
Q802	411020945P	TRS. 2SC945P TO-92 -RT-
Q803	411020945P	TRS. 2SC945P TO-92 -RT-
Q804	411020945P	TRS. 2SC945P TO-92 -RT-
Q901	410030669A	TRS. 2SD669A TO-126
Q902	41035010K0	TRS. FS10KM-12 TO-220F
Q903	4114501006	TRS. MCR100-6 TO-92 -RT-
Q904	4110105610	TRS. 2SB561 TO-92 -RT-
Q905	4116612030	TRS. RN1203 -RT-
Q906	410030669A	TRS. 2SD669A TO-126
Q915	411020945P	TRS. 2SC945P TO-92 -RT-

G800 Service Manual

REF.	PART NO.	DESCRIPTION
R101	4050530255	RES-CF 1/4W J 3K -AT- SMALL
R102	4050568255	RES-CF 1/4W J 6.8K SMALL -AT-
R103	4257041403	RES-PR MF 1/4W F 140K SMALL -A
R104	4050551255	RES-CF 1/4W J 5.1K -AT- SMALL
R105	4050510355	RES-CF 1/4W J 10K -AT- SMALL
R106	4050551255	RES-CF 1/4W J 5.1K -AT- SMALL
R107	4050510255	RES-CF 1/4W J 1K -AT- SMALL
R108	4050533255	RES-CF 1/4W J 3.3K -AT- SMALL
R109	4050510455	RES-CF 1/4W J 100K -AT- SMALL
R110	4050524055	RES-CF 1/4W J 24R SMALL -AT-
R111	4050520255	RES-CF 1/4W J 2K -AT- SMALL
R112	4050513155	RES-CF 1/4W J 130R SMALL -AT-
R114	4050547255	RES-CF 1/4W J 4.7K -AT- SMALL
R115	4172047056	RES-MOF 2W J 47R -AT-
R116	4171033956	RES-MOF 1W J 3.3R -AT-
R117	4050110155	RES-CF 1/2W J 100R SMALL -AT-
R118	4050116455	RES-CF 1/2W J 160K SMALL -AT-
R119	4050543455	RES-CF 1/4W J 430K SMALL -AT-
R120	4050543455	RES-CF 1/4W J 430K SMALL -AT-
R121	4050539255	RES-CF 1/4W J 3.9K -AT- SMALL
R122	4050568455	RES-CF 1/4W J 680K SMALL -AT-
R123	4050510055	RES-CF 1/4W J 10R -AT- SMALL
R125	4050547155	RES-CF 1/4W J 470R SMALL -AT-
R128	4050510255	RES-CF 1/4W J 1K -AT- SMALL
R129	4171075956	RES-MOF 1W J 7.5R -AT-
R130	4050547255	RES-CF 1/4W J 4.7K -AT- SMALL
R131	4050510355	RES-CF 1/4W J 10K -AT- SMALL
R132	4050522555	RES-CF 1/4W J 2.2M SMALL -AT-
R133	4050512355	RES-CF 1/4W J 12K -AT- SMALL
R136	4050510355	RES-CF 1/4W J 10K -AT- SMALL
R138	4050512455	RES-CF 1/4W J 120K -AT- SMALL
R139	4050533355	RES-CF 1/4W J 33K SMALL -AT-
R140	4050524355	RES-CF 1/4W J 24K -AT- SMALL
R145	4050513355	RES-CF 1/4W J 13K SMALL -AT-
R146	4050518355	RES-CF 1/4W J 18K SMALL -AT-
R148	4257021002	RES-PR MF 1/2W F 10K SMALL -AT
R149	4050515355	RES-CF 1/4W J 15K -AT- SMALL
R151	4050133155	RES-CF 1/2W J 330R -AT- SMALL
R152	4050510255	RES-CF 1/4W J 1K -AT- SMALL
R153	4050510255	RES-CF 1/4W J 1K -AT- SMALL
R156	4050511455	RES-CF 1/4W J 110K SMALL -AT-
R157	4050510255	RES-CF 1/4W J 1K -AT- SMALL
R201	4050510255	RES-CF 1/4W J 1K -AT- SMALL
R202	4050510355	RES-CF 1/4W J 10K -AT- SMALL
R203	4050510355	RES-CF 1/4W J 10K -AT- SMALL
R204	4050575455	RES-CF 1/4W J 750K SMALL -AT-
R205	4050511355	RES-CF 1/4W J 11K SMALL -AT-
R206	4050510255	RES-CF 1/4W J 1K -AT- SMALL
R207	4050520455	RES-CF 1/4W J 200K -AT- SMALL
R210	4050510355	RES-CF 1/4W J 10K -AT- SMALL
R211	4050510455	RES-CF 1/4W J 100K -AT- SMALL
R212	4050536355	RES-CF 1/4W J 36K -AT- SMALL
R213	4257044222	RES-PR MF 1/4W F 42.2K AT SMALL
R214	4257041504	RES-PR MF 1/4W F 1.5M SMALL -A
R215	4050520455	RES-CF 1/4W J 200K -AT- SMALL
R216	4257048251	RES-PR MF 1/4W F 8.25K AT SMALL
R218	4050547455	RES-CF 1/4W J 470K SMALL -AT-
R219	4257043922	RES-PR MF 1/4W F 39.2K AT SMALL
R220	4050512955	RES-CF 1/4W J 1.2R SMALL -AT-
R221	4050122155	RES-CF 1/2W J 220R -AT- SMALL

REF.	PART NO.	DESCRIPTION
R222	4257049532	RES-PR MF 1/4W F 95.3K AT SMALL
R223	4171015956	RES-MOF 1W J 1.5R -AT-
R224	4257041432	RES-PR MF 1/4W F 14.3K SMALL -
R225	4050547255	RES-CF 1/4W J 4.7K -AT- SMALL
R226	4050110255	RES-CF 1/2W J 1K SMALL -AT-
R227	4050510355	RES-CF 1/4W J 10K -AT- SMALL
R228	4050122255	RES-CF 1/2W J 2.2K SMALL -AT-
R229	4050510055	RES-CF 1/4W J 10R -AT- SMALL
R230	4172010953	RES-MOF 2W J 1R -SF-
R231	4050551155	RES-CF 1/4W J 510R SMALL -AT-
R232	4050510355	RES-CF 1/4W J 10K -AT- SMALL
R233	4050510255	RES-CF 1/4W J 1K -AT- SMALL
R234	4050524455	RES-CF 1/4W J 240K SMALL -AT-
R235	4257046342	RES-PR MF 1/4W F 63.4K SMALL -
R236	4257041432	RES-PR MF 1/4W F 14.3K SMALL -
R237	4050510355	RES-CF 1/4W J 10K -AT- SMALL
R238	4050520255	RES-CF 1/4W J 2K -AT- SMALL
R240	4050536355	RES-CF 1/4W J 36K -AT- SMALL
R241	4050510355	RES-CF 1/4W J 10K -AT- SMALL
R242	4050510355	RES-CF 1/4W J 10K -AT- SMALL
R243	4050512355	RES-CF 1/4W J 12K -AT- SMALL
R244	4050510355	RES-CF 1/4W J 10K -AT- SMALL
R245	4257047502	RES-PR MF 1/4W F 75K SMALL -AT
R246	4050539355	RES-CF 1/4W J 39K SMALL -AT-
R301	4257041962	RES-PR MF 1/4W F 19.6K SMALL -
R302	4257042742	RES-PR MF 1/4W F 27.4K SMALL -
R305	4050510155	RES-CF 1/4W J 100R -AT- SMALL
R306	4050520255	RES-CF 1/4W J 2K -AT- SMALL
R310	4050510255	RES-CF 1/4W J 1K -AT- SMALL
R311	4050510355	RES-CF 1/4W J 10K -AT- SMALL
R312	4257041102	RES-PR MF 1/4W F 11K AT SMALL
R313	4050518355	RES-CF 1/4W J 18K SMALL -AT-
R315	4050510455	RES-CF 1/4W J 100K -AT- SMALL
R316	4050510155	RES-CF 1/4W J 100R -AT- SMALL
R317	4171024156	RES-MOF 1W J 240R -AT-
R318	4172051053	RES-MOF 2W J 51R -SF-
R319	4171033956	RES-MOF 1W J 3.3R -AT-
R320	4172022953	RES-MOF J 2W 2.2R -SF-
R323	4257041502	RES-PR MF 1/4W F 15K AT SMALL
R324	4257045901	RES-PR MF 1/4W F 5.9K SMALL -A
R325	4050510355	RES-CF 1/4W J 10K -AT- SMALL
R326	4257043651	RES-PR MF 1/4W F 3.65K AT SMALL
R327	4050522255	RES-CF 1/4W J 2.2K -AT- SMALL
R328	4257044320	RES-PR MF 1/4W F 432R SMALL -A
R329	4257042432	RES-PR MF 1/4W F 24.3K SMALL -
R330	4182016153	RES-FUSIBLE 2W J 160R -SF-
R331	4257041004	RES-PR MF 1/4W F 1M SMALL -AT-
R332	4050547355	RES-CF 1/4W J 47K -AT- SMALL
R333	4171010256	RES-MOF 1W J 1K -AT-
R334	4172075856	RES-MOF 2W J 0.75R -AT-
R335	4050510255	RES-CF 1/4W J 1K -AT- SMALL
R336	4171010456	RES-MOF 1W J 100K -AT-
R346	4050551255	RES-CF 1/4W J 5.1K -AT- SMALL
R348	4050547255	RES-CF 1/4W J 4.7K -AT- SMALL
R349	4050510255	RES-CF 1/4W J 1K -AT- SMALL
R350	4050547255	RES-CF 1/4W J 4.7K -AT- SMALL
R351	4050510255	RES-CF 1/4W J 1K -AT- SMALL
R353	4050515255	RES-CF 1/4W J 1.5K SMALL -AT-
R354	4050510355	RES-CF 1/4W J 10K -AT- SMALL
R356	4050510355	RES-CF 1/4W J 10K -AT- SMALL

PCB Component List

REF.	PART NO.	DESCRIPTION
R357	4050510355	RES-CF 1/4W J 10K -AT- SMALL
R358	4050522155	RES-CF 1/4W J 220R SMALL -AT-
R359	4050510555	RES-CF 1/4W J 1M -AT- SMALL
R360	4050515355	RES-CF 1/4W J 15K -AT- SMALL
R361	4050568255	RES-CF 1/4W J 6.8K SMALL -AT-
R362	4050547255	RES-CF 1/4W J 4.7K -AT- SMALL
R363	4050510455	RES-CF 1/4W J 100K -AT- SMALL
R364	4050527355	RES-CF 1/4W J 27K -AT- SMALL
R366	4050510355	RES-CF 1/4W J 10K -AT- SMALL
R367	4257041002	RES-PR MF 1/4W F 10K AT SMALL
R368	4050510355	RES-CF 1/4W J 10K -AT- SMALL
R369	4257041002	RES-PR MF 1/4W F 10K AT SMALL
R370	4050510355	RES-CF 1/4W J 10K -AT- SMALL
R371	4050510155	RES-CF 1/4W J 100R -AT- SMALL
R380	4050522255	RES-CF 1/4W J 2.2K -AT- SMALL
R383	4050110455	RES-CF 1/2W J 100K SMALL -AT-
R384	4050522255	RES-CF 1/4W J 2.2K -AT- SMALL
R385	4050110455	RES-CF 1/2W J 100K SMALL -AT-
R386	4050522255	RES-CF 1/4W J 2.2K -AT- SMALL
R387	4050147455	RES-CF 1/2W J 470K -AT- SMALL
R388	4050110455	RES-CF 1/2W J 100K SMALL -AT-
R390	4050520355	RES-CF 1/4W J 20K -AT- SMALL
R391	4050516455	RES-CF 1/4W J 160K SMALL -AT-
R392	4050516455	RES-CF 1/4W J 160K SMALL -AT-
R393	4050510155	RES-CF 1/4W J 100R -AT- SMALL
R394	4177351053	RES-MOF 3W J 51R -SF- SMALL
R395	4050133155	RES-CF 1/2W J 330R -AT- SMALL
R396	4177320353	RES-MOF 3W J 20K -SF- SMALL
R397	4177320353	RES-MOF 3W J 20K -SF- SMALL
R399	4050515355	RES-CF 1/4W J 15K -AT- SMALL
R3A0	4172022953	RES-MOF J 2W 2.2R -SF-
R3A1	4050510355	RES-CF 1/4W J 10K -AT- SMALL
R3A2	4171022056	RES-MOF 1W J 22R -AT-
R3A3	4257044021	RES-PR MF 1/4W F 4.02K SMALL
R3A4	4050512455	RES-CF 1/4W J 120K -AT- SMALL
R3A5	4050510455	RES-CF 1/4W J 100K -AT- SMALL
R3A6	4050510155	RES-CF 1/4W J 100R -AT- SMALL
R3A7	4257043011	RES-PR MF 1/4W F 3.01K SMALL
R3A8	4050510155	RES-CF 1/4W J 100R -AT- SMALL
R3A9	4257043922	RES-PR MF 1/4W F 39.2K AT SMAL
R3B3	4050568255	RES-CF 1/4W J 6.8K SMALL -AT-
R3B4	4050547255	RES-CF 1/4W J 4.7K -AT- SMALL
R3B5	4257041002	RES-PR MF 1/4W F 10K AT SMALL
R3B6	4257041911	RES-PR MF 1/4W F 1.91K AT SMAL
R3B7	4050513355	RES-CF 1/4W J 13K SMALL -AT-
R3B8	4257042372	RES-PR MF 1/4W F 23.7K SMALL
R3B9	4050533255	RES-CF 1/4W J 3.3K -AT- SMALL
R3C1	4050515455	RES-CF 1/4W J 150K SMALL -AT-
R3C2	4171019056	RES-MOF 1W J 18R -AT-
R3C3	4171056056	RES-MOF 1W J 56R -AT-
R601	4050522955	RES-CF 1/4W J 2.2R SMALL -AT-
R602	4050518255	RES-CF 1/4W J 1.8K -AT- SMALL
R603	4050510355	RES-CF 1/4W J 10K -AT- SMALL
R604	4050510355	RES-CF 1/4W J 10K -AT- SMALL
R605	4050522255	RES-CF 1/4W J 2.2K -AT- SMALL
R606	4050539255	RES-CF 1/4W J 3.9K -AT- SMALL
R607	4050536353	RES-CF 1/4W J 36K -AT- SMALL
R608	4050512455	RES-CF 1/4W J 120K -AT- SMALL
R609	4257042212	RES-PR MF 1/4W F 22.1K SMALL
R610	4257041622	RES-PR MF 1/4W F 16.2K SMALL

REF.	PART NO.	DESCRIPTION
R611	4050568255	RES-CF 1/4W J 6.8K SMALL -AT-
R612	4050510355	RES-CF 1/4W J 10K -AT- SMALL
R613	4050510255	RES-CF 1/4W J 1K -AT- SMALL
R614	4050547355	RES-CF 1/4W J 47K -AT- SMALL
R615	4050522255	RES-CF 1/4W J 2.2K -AT- SMALL
R616	4050182055	RES-CF 1/2W J 82R SMALL -AT-
R617	4050510055	RES-CF 1/4W J 10R -AT- SMALL
R618	4050512355	RES-CF 1/4W J 12K -AT- SMALL
R619	4050168155	RES-CF 1/2W J 680R -AT- SMALL
R620	4050551155	RES-CF 1/4W J 510R SMALL -AT-
R621	4050551255	RES-CF 1/4W J 5.1K -AT- SMALL
R801	4050551055	RES-CF 1/4W J 51R -AT- SMALL
R802	4050547255	RES-CF 1/4W J 4.7K -AT- SMALL
R803	4050547255	RES-CF 1/4W J 4.7K -AT- SMALL
R804	4050510155	RES-CF 1/4W J 100R -AT- SMALL
R805	4050591255	RES-CF 1/4W J 9.1K SMALL -AT-
R806	4050547255	RES-CF 1/4W J 4.7K -AT- SMALL
R807	4050575155	RES-CF 1/4W J 750R SMALL -AT-
R808	4050520255	RES-CF 1/4W J 2K -AT- SMALL
R809	4050547255	RES-CF 1/4W J 4.7K -AT- SMALL
R810	4050547255	RES-CF 1/4W J 4.7K -AT- SMALL
R811	4050547255	RES-CF 1/4W J 4.7K -AT- SMALL
R812	4050547255	RES-CF 1/4W J 4.7K -AT- SMALL
R813	4050510255	RES-CF 1/4W J 1K -AT- SMALL
R814	4050582255	RES-CF 1/4W J 8.2K -AT- SMALL
R816	4050510155	RES-CF 1/4W J 100R -AT- SMALL
R817	4050510155	RES-CF 1/4W J 100R -AT- SMALL
R818	4050547255	RES-CF 1/4W J 4.7K -AT- SMALL
R819	4050510455	RES-CF 1/4W J 100K -AT- SMALL
R820	4050510455	RES-CF 1/4W J 100K -AT- SMALL
R821	4050510255	RES-CF 1/4W J 1K -AT- SMALL
R822	4050575155	RES-CF 1/4W J 750R SMALL -AT-
R823	4050568155	RES-CF 1/4W J 680R SMALL -AT-
R824	4050510355	RES-CF 1/4W J 10K -AT- SMALL
R825	4050510355	RES-CF 1/4W J 10K -AT- SMALL
R826	4050510255	RES-CF 1/4W J 1K -AT- SMALL
R827	4050522255	RES-CF 1/4W J 2.2K -AT- SMALL
R828	4050510255	RES-CF 1/4W J 1K -AT- SMALL
R829	4050547255	RES-CF 1/4W J 4.7K -AT- SMALL
R901	710501003B	THMER. +/-15% 10R 5A 15c W/KINK
R902	4171033856	RES-MOF 1W J 0.33R -AT-
R903	4172036353	RES-MOF 2W J 36K -SF-
R904	4172036353	RES-MOF 2W J 36K -SF-
R905	409501035E	RES-WW 5W J 10K
R906	409702025H	RES-WW 7W J 2K
R907	4050124355	RES-CF 1/2W J 24K -AT- SMALL
R909	4050527255	RES-CF 1/4W J 2.7K -AT- SMALL
R910	4050518055	RES-CF 1/4W J 18R -AT- SMALL
R911	4050539055	RES-CF 1/4W J 39R -AT- SMALL
R912	4257045761	RES-PR MF 1/4W F 5.76K SMALL
R914	4172033853	RES-MOF 2W J 0.33R -SF-
R915	4050524255	RES-CF 1/4W J 2.4K SMALL -AT-
R916	4050520255	RES-CF 1/4W J 2K -AT- SMALL
R918	4050515355	RES-CF 1/4W J 15K -AT- SMALL
R920	4050510255	RES-CF 1/4W J 1K -AT- SMALL
R921	4050551255	RES-CF 1/4W J 5.1K -AT- SMALL
R922	4050551255	RES-CF 1/4W J 5.1K -AT- SMALL
R923	4050524055	RES-CF 1/4W J 24R SMALL -AT-
R924	4050520155	RES-CF 1/4W J 200R -AT- SMALL
R925	4050516155	RES-CF 1/4W J 160R SMALL -AT-

G800 Service Manual

REF.	PART NO.	DESCRIPTION
R926	4050551255	RES-CF 1/4W J 5.1K -AT- SMALL
R927	4050515355	RES-CF 1/4W J 15K -AT- SMALL
R928	4050582255	RES-CF 1/4W J 8.2K -AT- SMALL
R929	4050515355	RES-CF 1/4W J 15K -AT- SMALL
R930	4050510355	RES-CF 1/4W J 10K -AT- SMALL
R931	4050510155	RES-CF 1/4W J 100R -AT- SMALL
R932	4050522155	RES-CF 1/4W J 220R SMALL -AT-
R933	4050510155	RES-CF 1/4W J 100R -AT- SMALL
R934	4050547155	RES-CF 1/4W J 470R SMALL -AT-
R935	4050536155	RES-CF 1/4W J 360R SMALL -AT-
R936	4050520255	RES-CF 1/4W J 2K -AT- SMALL
R937	4257048872	RES-PR MF 1/4W F 88.7K SMALL -
R938	4050510255	RES-CF 1/4W J 1K -AT- SMALL
R939	4257041432	RES-PR MF 1/4W F 14.3K SMALL -
R940	4257043831	RES-PR MF 1/4W F 3.83K SMALL -
R941	4257041273	RES-PR MF 1/4W F 127K SMALL -A
R942	4050551255	RES-CF 1/4W J 5.1K -AT- SMALL
R943	4172033353	RES-MOF 2W J 33K -SF-
R950	4182012953	RES-FUSIBLE 2W J 1.2R -SF-
R953	4050151055	RES-CF 1/2W J 51R -AT- SMALL
R955	4050562055	RES-CF 1/4W J 62R SMALL -AT-
R956	4050182455	RES-CF 1/2W J 820K SMALL -AT-
R957	4050515555	RES-CF 1/4W J 1.5M SMALL -AT-
R958	4050510255	RES-CF 1/4W J 1K -AT- SMALL
R959	4050156555	RES-CF 1/2W J 5.6M SMALL -AT-
R960	4050551055	RES-CF 1/4W J 51R -AT- SMALL
R961	4050551055	RES-CF 1/4W J 51R -AT- SMALL
R962	4050151055	RES-CF 1/2W J 51R -AT- SMALL
R964	4050515555	RES-CF 1/4W J 1.5M SMALL -AT-
R977	4050556555	RES-CF 1/4W J 5.6M SMALL -AT-
R978	4050520355	RES-CF 1/4W J 20K -AT- SMALL
R979	4050510355	RES-CF 1/4W J 10K -AT- SMALL
RL301	4420812005	RELAY JW 2HN-DC12V
RL301	4420412009	RELAY JW2aHN-DC12V
RN801	4082074725	RES-NET 7P J 4.7K COMMON
RN802	4082094725	RES-NET 9P J 4.7K COMMON

CAP-SCF 0.1UFZ 50V -RT-
CAP-CCSL 560PFJ 50V -RT-
CAP-CCCH 39PFJ 50V -RT-
CAP-MEF 0.1UFJ 100V CF
CAP-EC6 1UFM 100V -RT-
CAP-X7R 0.1UFM 100V -RT-
CAP-ECX 47UFM 100V -SF-
CAP-CCB 0.01UFM 1KV -SF-
CAP-CCE 1000PFM 3KV -SF-
CAP-EC6 100UFM 16V -RT-
CAP-CCCH 100PFJ 50V -RT-
CAP-SCF 0.1UFZ 50V -RT-
CAP-SCF 0.1UFZ 50V -RT-
CAP-SCF 0.1UFZ 50V -RT-
CAP-CCCH 100PFJ 50V -RT-
CAP-EC6 1UFM 50V -RT-
CAP-X7R 0.1UFM 100V -RT-
CAP-X7R 0.1UFM 100V -RT-
CAP-SCF 0.1UFZ 50V -RT-

T102	7050917T10	O/P TRANSFORMER
T103	7050302H20	F.B.T.
T104	7050502H20	FOCUS TRANSFORMER
T301	7050207H10	H-DRIVER TRANSFORMER
T601	7177H10000	TRANSDUCER CURRENT SENSOR
T602	7050957H10	H-TRANSFORMER (O/P)
T603	705025423L	DRIVER TRANSFORMER
T902	7067H10303	CHOKE COMMON MODE
T903	7050102H20	POWER TRANSFORMER
VR101	5225110410	POT(CERMET) 0.3W 100K 6c LAY-D
VR102	5221150300	POT(CERMET) 0.3W 50K 6c STAND-
VR106	5225150310	POT(CERMET) 0.3W 50K 6c LAY-DO
VR107	5225110410	POT(CERMET) 0.3W 100K 6c LAY-D
X801	7154000005	CRYSTAL 4.00MHz
ZD101	4120510160	Z-D Z10-160B 1W 160V +-5% DO-4
ZD302	41205091CU	DIODE ZENER MTZJ9.1C -AT-
ZD336	4120500152	DIODE ZENER 14.5-15.1V -AT-
ZD370	4120500152	DIODE ZENER 14.5-15.1V -AT-
ZD387	4120500152	DIODE ZENER 14.5-15.1V -AT-

C51	5134104452
C53	5128561552
C54	5121390552
C55	5075104501
C59	5156109701
C80	7140104214
C81	515X470501
C82	5101103233
C83	5103102293
C84	5156101T16
C7	5121101552
C70	5134104452
C71	5134104452
C72	5134104452
C74	5121101552
C75	5156109750
C76	7140104214
C77	7140104214
C78	5134104452

9.3. Neck Board

REF.	PART NO.	DESCRIPTION
	TH2H200244-V	NECK PCB ASSY
	2009191530	HEAT SINK FOR IC1
	3011100030	NUT ISO HEX M3 Z1NC FOR IC1
	4141118900	#P C.B. NECK
	4491200300	BASE 12P 2.54MM SXB-XH-A FOR P1
	8026113010	SCREW BIND(+) TAPPING M3X10 TR FOR PCB & IC1 HEAT SINK
	8504113016	SCREW BID(+) MACH WD ZINC M3X16 FOR IC1
	C459433L60	GND WIRE ASSY FOR NECK PCB TO SHIELD
C1	5156100T50	CAP-EC6 10UFM 50V -RT-
C10	5134104452	CAP-SCF 0.1UFZ 50V -RT-
C13	5134104452	CAP-SCF 0.1UFZ 50V -RT-
C19	5156101T16	CAP-EC6 100UFM 16V -RT-
C2	5134104452	CAP-SCF 0.1UFZ 50V -RT-
C3	515X101T16	CAP-ECX 100UFM 16V -RT-
C30	5156100T50	CAP-EC6 10UFM 50V -RT-
C31	5134104452	CAP-SCF 0.1UFZ 50V -RT-
C32	5156109750	CAP-EC6 1UFM 50V -RT-
C33	5134104452	CAP-SCF 0.1UFZ 50V -RT-
C34	5121390552	CAP-CCCH 39PFJ 50V -RT-

G800 Service Manual

REF.	PART NO.	DESCRIPTION
R50	4257041479	RES-PR MF 1/4W F 14.7R SMALL -
R51	4257048049	RES-PR MF 1/4W F 60.4R SMALL -
R52	4050533055	RES-CF 1/4W J 33R -AT- SMALL
R53	4050510055	RES-CF 1/4W J 10R -AT- SMALL
R54	4050522155	RES-CF 1/4W J 220R SMALL -AT-
R55	4050510255	RES-CF 1/4W J 1K -AT- SMALL
R56	4050510055	RES-CF 1/4W J 10R -AT- SMALL
R57	4050510155	RES-CF 1/4W J 100R -AT- SMALL
R58	4050510055	RES-CF 1/4W J 10R -AT- SMALL
R6	4050510055	RES-CF 1/4W J 10R -AT- SMALL
R60	4050510555	RES-CF 1/4W J 1M -AT- SMALL
R61	4050512355	RES-CF 1/4W J 12K -AT- SMALL
R64	4060247015	RES-CC 1/2W K 47R -AT-
R65	4050515255	RES-CF 1/4W J 1.5K SMALL -AT-
R66	4050162155	RES-CF 1/2W J 620R SMALL -AT-
R67	4050510355	RES-CF 1/4W J 10K -AT- SMALL
R68	4050547155	RES-CF 1/4W J 470R SMALL -AT-
R69	4060251315	RES-CC 1/2W K 51K -AT-
R7	4050510155	RES-CF 1/4W J 100R -AT- SMALL
R70	4050527255	RES-CF 1/4W J 2.7K -AT- SMALL
R71	4050527255	RES-CF 1/4W J 2.7K -AT- SMALL
R72	4050522255	RES-CF 1/4W J 2.2K -AT- SMALL
R73	4050530455	RES-CF 1/4W J 300K SMALL -AT-
R74	4050510455	RES-CF 1/4W J 100K -AT- SMALL
R75	4050547355	RES-CF 1/4W J 47K -AT- SMALL
R77	4050533055	RES-CF 1/4W J 33R -AT- SMALL
R78	4050568155	RES-CF 1/4W J 680R SMALL -AT-
R79	4050533055	RES-CF 1/4W J 33R -AT- SMALL
R8	4050510055	RES-CF 1/4W J 10R -AT- SMALL
R82	4050515255	RES-CF 1/4W J 1.5K SMALL -AT-
R83	4050510255	RES-CF 1/4W J 1K -AT- SMALL
R84	4050510555	RES-CF 1/4W J 1M -AT- SMALL
R85	4050510155	RES-CF 1/4W J 100R -AT- SMALL
R86	4050510155	RES-CF 1/4W J 100R -AT- SMALL
R87	4050522455	RES-CF 1/4W J 220K SMALL -AT-
R88	4050510255	RES-CF 1/4W J 1K -AT- SMALL
R90	4257042401	RES-PR MF 1/4W F 2.4K AT SMALL
R91	4050510155	RES-CF 1/4W J 100R -AT- SMALL
R98	4181015256	RES-FUSIBLE 1W J 1.5K -AT-
R99	4050522255	RES-CF 1/4W J 2.2K -AT- SMALL
SG7	5106152304	SPARK GAP 1.5KV AG-15 P:6.4mm
ZD70	41205051AU	DIODE ZENER MTZJ5.1A -AT-
ZD71	41205051AU	DIODE ZENER MTZJ5.1A -AT-
ZD72	41205036AU	DIODE ZENER MTZJ3.6A -AT-
ZD73	41205051AU	DIODE ZENER MTZJ5.1A -AT-
ZD74	41205091CU	DIODE ZENER MTZJ9.1C -AT-
ZD75	41205051AU	DIODE ZENER MTZJ5.1A -AT-

9.4. Control Board

REF.	PART NO.	DESCRIPTION
	TH2H220444-V	CONTROL PCB ASS'Y
	3622300053	LED HOLDER FOR HOLD
	4141119900	#P.C.B. CONTROL
	C488100026	CONN. 10P & WIRE ASSY 200mm FOR P805
D816	4120141480	DIODE 1N4148 (SI) -AT-

REF.	PART NO.	DESCRIPTION
D817	4120141480	DIODE 1N4148 (SI) -AT-
LD201	4120664630	LED LT6463-23-D51 5e G/Y
S801	4410604040	KEYSWITCH TACT SKH-HAM2520 1KE
S802	4410604040	KEYSWITCH TACT SKH-HAM2520 1KE
S803	4410604040	KEYSWITCH TACT SKH-HAM2520 1KE
S804	4410604040	KEYSWITCH TACT SKH-HAM2520 1KE

9.5. Different List

MODEL NO. : RTH 2H22

REF.	PART NO.	DESCRIPTION
	463110000N	AC POWERCORDPC VDEGRY 6FT W

MODEL NO. : RTH 2H23

REF.	PART NO.	DESCRIPTION
	463310000N	AC POWERCORDWALL 6FT GRY UL

PCB Component List

REF.	PART NO.	DESCRIPTION
C79	5156102S16	CAP-EC6 1000UFM 16V -SF-
C8	5101102152	CAP-CCB 1000PFK 50V -RT-
C81	7140104214	CAP-X7R 0.1UFM 100V -RT-
C83	5101222152	CAP-CCB 2200PFK 50V -RT-
C85	5134104452	CAP-SCF 0.1UFZ 50V -RT-
C86	5116472111	CAP-MC 0.0047UFK 100V -RT-
C87	5134104452	CAP-SCF 0.1UFZ 50V -RT-
C88	5156101T16	CAP-EC6 100UFM 16V -RT-
C89	5156109T50	CAP-EC6 1UFM 50V -RT-
C9	515X109T50	CAP-ECX 1UFM 50V -RT-
C90	5134104452	CAP-SCF 0.1UFZ 50V -RT-
C91	5101102152	CAP-CCB 1000PFK 50V -RT-
C92	5134104452	CAP-SCF 0.1UFZ 50V -RT-
C93	5134104452	CAP-SCF 0.1UFZ 50V -RT-
C94	5134104452	CAP-SCF 0.1UFZ 50V -RT-
C95	5134104452	CAP-SCF 0.1UFZ 50V -RT-
C96	515X109T50	CAP-ECX 1UFM 50V -RT-
C97	5156100T50	CAP-EC6 10UFM 50V -RT-
C98	5134104452	CAP-SCF 0.1UFZ 50V -RT-
C99	5134104452	CAP-SCF 0.1UFZ 50V -RT-
CRT1	457030423H	SOCKET CRT HPS0380-01-110
D1	4120141480	DIODE 1N4148 (SI) -AT-
D2	4120141480	DIODE 1N4148 (SI) -AT-
D30	4120141480	DIODE 1N4148 (SI) -AT-
D31	4120141480	DIODE 1N4148 (SI) -AT-
D34	413258020U	DIODE BAV20 DO-35 -AT-
D35	413258020U	DIODE BAV20 DO-35 -AT-
D36	413258020U	DIODE BAV20 DO-35 -AT-
D37	4120141480	DIODE 1N4148 (SI) -AT-
D4	413258020U	DIODE BAV20 DO-35 -AT-
D5	413258020U	DIODE BAV20 DO-35 -AT-
D50	4120141480	DIODE 1N4148 (SI) -AT-
D51	4120141480	DIODE 1N4148 (SI) -AT-
D54	413258020U	DIODE BAV20 DO-35 -AT-
D55	413258020U	DIODE BAV20 DO-35 -AT-
D56	413258020U	DIODE BAV20 DO-35 -AT-
D57	4120141480	DIODE 1N4148 (SI) -AT-
D6	413258020U	DIODE BAV20 DO-35 -AT-
D7	4120141480	DIODE 1N4148 (SI) -AT-
D70	4120141480	DIODE 1N4148 (SI) -AT-
D71	4120141480	DIODE 1N4148 (SI) -AT-
D72	4120141480	DIODE 1N4148 (SI) -AT-
D74	4120141480	DIODE 1N4148 (SI) -AT-
D75	4120141480	DIODE 1N4148 (SI) -AT-
D79	4120141480	DIODE 1N4148 (SI) -AT-
D80	4120141480	DIODE 1N4148 (SI) -AT-
D81	413010426C	DIODE BYV26C KINK FORMING -AT-
D83	4120141480	DIODE 1N4148 (SI) -AT-
D84	4120141480	DIODE 1N4148 (SI) -AT-
D85	4120141480	DIODE 1N4148 (SI) -AT-
FB11	4322309006	FERRITE BEAD 3UH -AT-
FB12	4322309006	FERRITE BEAD 3UH -AT-
FB70	4322309006	FERRITE BEAD 3UH -AT-
FB71	4322309006	FERRITE BEAD 3UH -AT-
FB72	4322309006	FERRITE BEAD 3UH -AT-
FB73	4322309006	FERRITE BEAD 3UH -AT-
FB74	4322309006	FERRITE BEAD 3UH -AT-
FB75	4322309006	FERRITE BEAD 3UH -AT-
FB78	4322309006	FERRITE BEAD 3UH -AT-
FB79	4322209046	FERRITE BEAD 2UH -AT-

REF.	PART NO.	DESCRIPTION
IC1	4159001000	IC VPS10S 15PIN
IC2	4159350433	IC M35043-058SP 20PIN SMH7N10
IC3	4159120500	IC LM1205N 28PIN
IC4	4159393000	IC LM 393 8PIN
IC5	41598444N0	IC TDA8444N 16PIN
L1	4321478006	COIL PEAKING 0.47UH -AT-
L31	4321478006	COIL PEAKING 0.47UH -AT-
L51	4321478006	COIL PEAKING 0.47UH -AT-
Q2	4111139040	TRS. 2N3904 TO-92 -RT-
Q3	4110219210	TRS. 2SC1921 TO-92M -RT-
Q33	4110219210	TRS. 2SC1921 TO-92M -RT-
Q4	4111139040	TRS. 2N3904 TO-92 -RT-
Q5	4110007330	TRS. 2SA733 TO-92M -RT-
Q53	4110219210	TRS. 2SC1921 TO-92M -RT-
Q6	4110007330	TRS. 2SA733 TO-92M -RT-
Q7	4110007330	TRS. 2SA733 TO-92M -RT-
Q70	4116612030	TRS. RN1203 -RT-
Q72	4111139040	TRS. 2N3904 TO-92 -RT-
Q73	4111139040	TRS. 2N3904 TO-92 -RT-
Q74	4116610010	TRS. RN1001 -RT-
R1	4257047509	RES-PR MF 1/4W J 75R AT SMALL
R10	4050510555	RES-CF 1/4W J 1M -AT- SMALL
R11	4050512355	RES-CF 1/4W J 12K -AT- SMALL
R14	4060247015	RES-CC 1/2W K 47R -AT-
R15	4050515255	RES-CF 1/4W J 1.5K SMALL -AT-
R16	4050162155	RES-CF 1/2W J 620R SMALL -AT-
R17	4050510355	RES-CF 1/4W J 10K -AT- SMALL
R18	4050551155	RES-CF 1/4W J 510R SMALL -AT-
R19	4050510155	RES-CF 1/4W J 100R -AT- SMALL
R2	4050533055	RES-CF 1/4W J 33R -AT- SMALL
R20	4050510055	RES-CF 1/4W J 10R -AT- SMALL
R21	4050133955	RES-CF 1/2W J 3.3R -AT- SMALL
R22	4257046811	RES-PR MF 1/4W F 6 51K SMALL -
R23	4257041001	RES-PR MF 1/4W F 1K AT SMALL
R24	4050582355	RES-CF 1/4W J 82K -AT- SMALL
R25	4050515155	RES-CF 1/4W J 150R SMALL -AT-
R26	4050522255	RES-CF 1/4W J 2.2K -AT- SMALL
R27	4050522255	RES-CF 1/4W J 2.2K -AT- SMALL
R28	4050518555	RES-CF 1/4W J 1.8M SMALL -AT-
R29	4060210115	RES-CC 1/2W K 100R -AT-
R3	4050510055	RES-CF 1/4W J 10R -AT- SMALL
R30	4050522055	RES-CF 1/4W J 22R SMALL -AT-
R31	4257047509	RES-PR MF 1/4W F 75R AT SMALL
R32	4050533055	RES-CF 1/4W J 33R -AT- SMALL
R33	4050510055	RES-CF 1/4W J 10R -AT- SMALL
R34	4050522155	RES-CF 1/4W J 220R SMALL -AT-
R35	4050510255	RES-CF 1/4W J 1K -AT- SMALL
R36	4050510055	RES-CF 1/4W J 10R -AT- SMALL
R37	4050510155	RES-CF 1/4W J 100R -AT- SMALL
R38	4050510055	RES-CF 1/4W J 10R -AT- SMALL
R4	4050522155	RES-CF 1/4W J 220R SMALL -AT-
R40	4050510555	RES-CF 1/4W J 1M -AT- SMALL
R41	4050512355	RES-CF 1/4W J 12K -AT- SMALL
R44	4060247015	RES-CC 1/2W K 47R -AT-
R45	4050515255	RES-CF 1/4W J 1.5K SMALL -AT-
R46	4050162155	RES-CF 1/2W J 620R SMALL -AT-
R47	4050510355	RES-CF 1/4W J 10K -AT- SMALL
R48	4050547255	RES-CF 1/4W J 4.7K -AT- SMALL
R49	4050547255	RES-CF 1/4W J 4.7K -AT- SMALL
R5	4050510355	RES-CF 1/4W J 10K -AT- SMALL

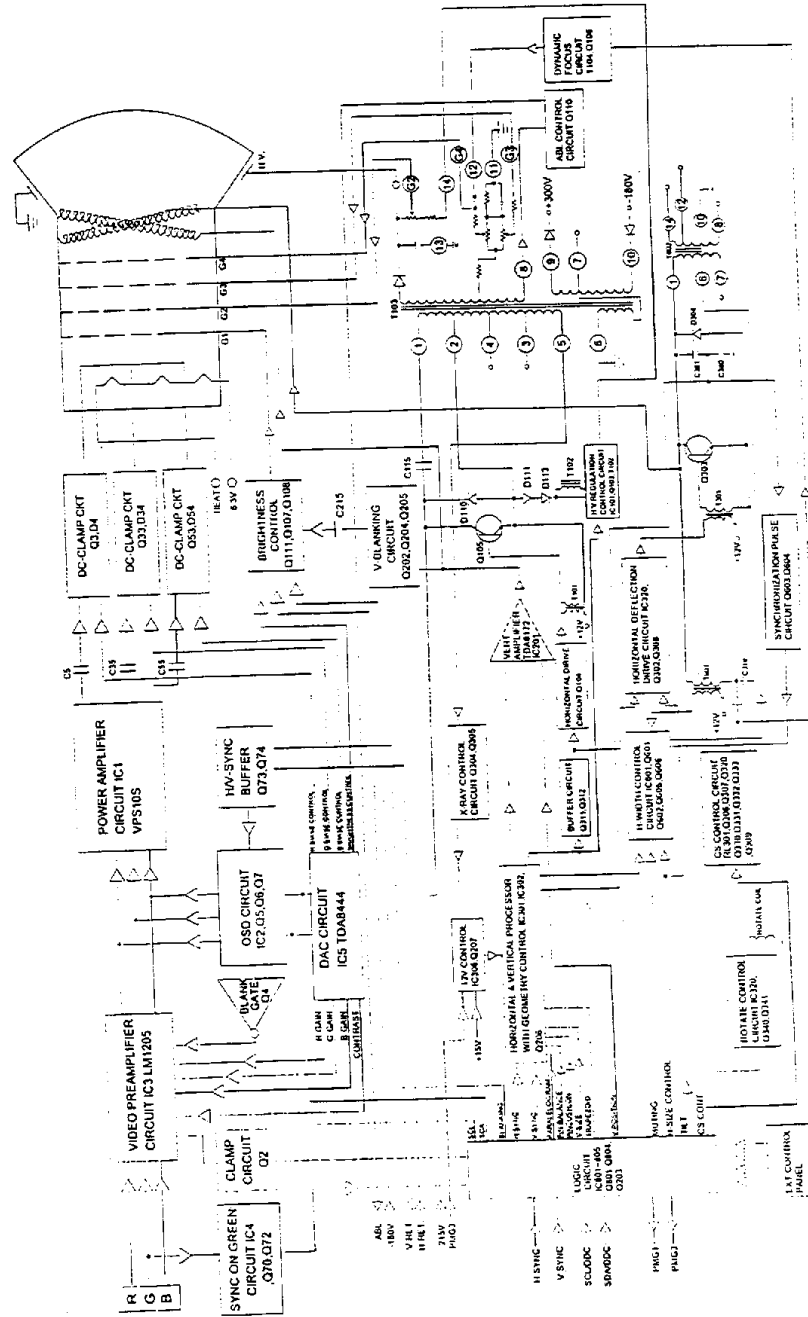

Figure 3-2 Video, Logic, Audio and Deflection Block Diagram